



INSTALLATION & OPERATION MANUAL

EXPLORE SERIES E6 & E7 TH



Preface

READ AND FOLLOW ALL INSTRUCTIONS IN THIS MANUAL

 **CAUTION**
(Risk Group 2): Possibly hazardous optical radiation emitted from this product. Do not stare at the operating lamp. Maybe harmful to the eye.

 **WARNINGS**
Prior to installing your OceanLED Light, carefully review and adhere to all included safety warnings and instructions to prevent potential property damage, serious injury, or fatality. Furthermore, ensure compliance with local regulations regarding the use of coloured lighting in your area.

Do not operate lights out of water for a period longer than 5 minutes followed by an OFF period of at least 1 hour. Exceeding this may cause damage to the light unit.

Ensure the bonding point of the light is fitted to the cathodic protection system on the vessel. Check conductivity between earth bonding point and aluminium bronze front bezel. If mounting the light to metal, carbon fibre or wooden hull, ensure that suitable measures have been put in place to account for the effects of galvanic corrosion or wood deterioration, i.e., use of Delrin sleeve components (Isolation Kit).

Salt is highly corrosive, especially to metal and certain surfaces. While OceanLED lights use saltwater-resistant materials, installation screws and fasteners must be marine-grade stainless steel or equivalent and should be inspected annually to ensure long-term performance.

Never connect/disconnect lights with power applied as irreversible damage may occur. Ensure polarity of power connections is correct. Failure to do this may invalidate the warranty.

Explore E6 & E7 TH light is for mounting directly to a flat surface. Ensure front of lights are always fully submerged and not fitted on planning / running surfaces that may impact on water since this may damage the product. Also ensure the rear of the light is in a dry area and not subject to a wet environment. Failure to do this may invalidate the warranty.

Do not submerge your cable ends in water; cable and connections exposed to underwater submersion will not be covered by warranty.

Never Use Solvents! Cleaners, fuel, and other products that may contain strong solvents, such as acetone, that attack many plastics greatly reducing their strength and irreversibly damaging the special lens coatings and cable sheathings.

Never clean lights using a high-pressure jet wash – this will invalidate warranty.

Do not coat the light's glass/lens with any product, including but not limited to clear antifouling paints or similar, without consulting OceanLED for advice. Failure to do so will void your warranty.

If bottom painting ensure the coating is applied as instructed in the “Finalising The Installation” section. Failure to do so will invalidate your warranty.

 **DANGER**
RISK OF ELECTRIC SHOCK OR ELECTROCUTION

This underwater light must be installed by a licensed or certified electrician in accordance with all applicable local codes and ordinances. Improper installation will create an electrical hazard which could result in death or serious injury to swimmers, installers, or others due to electrical shock, and may also cause damage to property. Always disconnect the power to the light at the circuit breaker before servicing the light.

Contents

1 Installation Checklist.....	3
2 Overview	4
3 Preparing the Hull	6
4 Installation.....	7
4.1 Installing The Light Fixture.....	7
4.2 Installation Of The Driver With The AC Power Kit.....	13
4.3 Installation Of The Driver With The DC Power Kit.....	16
4.4 Control System Installation.....	19
4.5 Finalising The Installation	23
4.6 Test Your Installation	23
5 Operation / Maintenance	24
5.1 Operation	24
5.2 Maintenance.....	25
5.3 Replacement Parts	25
6 Troubleshooting	26
6.1 Troubleshooting Problems And Their Solutions.....	26
7 Appendix	30
7.1 Overall Dimensions.....	30
7.2 Essential Test.....	31
7.3 Light Setup	32
7.4 Cable Gauge Chart 12V.....	34
7.5 Cable Gauge Chart 24V	35
7.6 Explore TH Angled Beam Details	36
7.7 Example Of The DC Installation Of Mixed XFM And TH E6 & E7 Lights.....	37
8 Warranty.....	39

PRE-TEST

Always test the lights prior to installation. Failure to do this may result in additional installation time and could invalidate the warranty.

IMPORTANT NOTICE

Attention Installer: This manual contains important information about the installation, operation and safe use of this product. This information should be given to the owner and/ or operator of this equipment.

WARRANTY COVERAGE

Please refer to www.oceanled.com/warranty for full warranty statement.

1 Installation Checklist

1. Decide on light spacing – OceanLED recommendations available. Rear of lights must never be exposed to wet environments inside the hull.
2. Decide on light angles (only applies for E7 installs) – OceanLED Personalised Service available on request. *The Explore E6/E7 TH lights can also be mixed with the Explore E6/E7 XFM – Please refer to Appendix Section 7.7 for the installation example.*
3. Ensure the correct power kit is selected and installed (AC or DC power kit).
4. Ensure correct cable gauge is used (refer to relevant cable gauge chart).
5. Control system chosen (switch control, OceanLED DMX control kit, 3rd party DMX control). Max 32 lights per DMX chain (as per recommended by the DMX standard).
6. Preparing the hull (Isolation kit required for conductive hull materials or wooden hulls).
7. Ensure the lights have been fitted in the correct orientation, and with the correct beam angle.
8. Find the appropriate dry location for the driver and AC power pack if used.
9. Correct marine sealant applied evenly around the bezel. Ensure fully watertight seal is created after sealant cures.
10. Correct clamping of light fixture onto hull. Never leave vessel unchecked for a few days after install. Always check routinely for a few days after installation to ensure the install is correct and fully sealed.
11. Light(s) correctly bonded and vessel bonding system check carried out (refer to relevant schematic and test procedures).
12. Test installation BEFORE entering water. Never connect/ disconnect lights whilst powered ON. Never leave lights ON out of water for longer than 5 minutes followed by an off period of 1 hour.
13. Troubleshooting if required - most issues can be resolved by following the guidelines.

2 Overview

Identifying your model

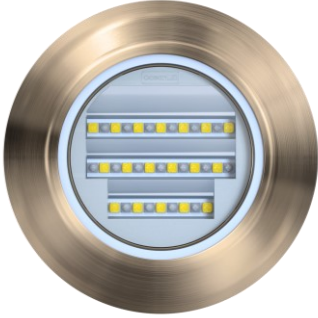

Explore E6/E7 TH Dual Blue/White

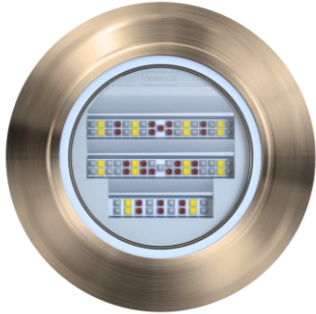

Explore E6/E7 TH Colours DMX

Kit Includes

Explore TH Basic Kit

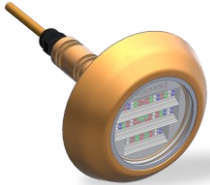

Explore TH Light
(with 2m Connection Cable)

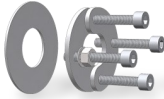

Clamping Kit



DC Driver

+

Or

Explore DC Power Kit



Power Cable 1.5m



Fuse

Explore AC Power Kit



AC Power Pack
(110/220V AC to 24V DC)



Power Link Cable 1.5m

Product Components Breakdown

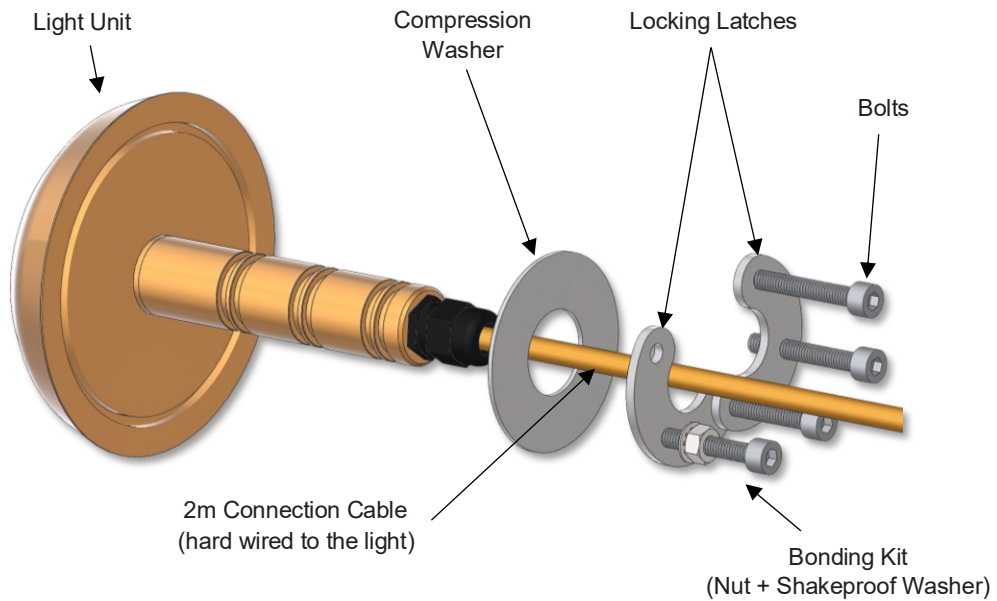

Power Source

Most installations will utilize on-board 12/24V DC power supply from a marine battery in which case the Explore DC Power Kit should be purchased. If AC power is being used on the vessel, an Explore AC Power Kit must be purchased. Please check the Explore E6/E7 TH Light Choice Diagram available in the Appendix (Section 7.3) to evaluate all the options currently offered by OceanLED.

Use the chart below to determine the power supply requirements.

Power Consumption and Recommended Fuse Values

Model	Current @ 12V DC	Current @ 24V DC	Max Nominal Power consumption	Minimum PSU Power (15% reserve)	Recommended fuse 12V/24V DC
E6/E7 TH Dual White/Blue	7.8 A	4.7 A	113W	130W	10 A
E6/E7 TH Colour DMX	6.8 A	3.2 A	82W	94W	10 A

3 Preparing the Hull

 The Explore TH unit requires an additional 60mm / 2.36” free space from the rear of the light body to allow for the cable clearance. (See overall dimensions in the Appendix).

OceanLED recommends using a qualified installer / technician when making modifications to your vessel. Please also consult the manufacturer for more detail on modifications and installation.

If lights are to be fitted to a conductive or wooden hull, an Isolation Kit must be used. Contact OceanLED for additional details.

DELTRIN ISOLATION KIT

Isolation of the metal parts of the Explore TH Series Light from conductive or wooden hulls to prevent galvanic corrosion issues. The isolation kit is easily fitted to the rear of the light fixture using a suitable adhesive.

PART NUMBER

019914 - E-TH Delrin Isolation Sleeve Kit

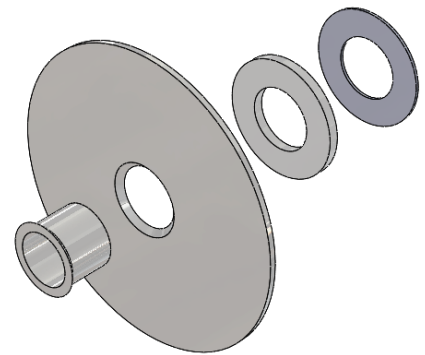

For the correct orientation of the light, the logo should typically face upwards and parallel with the water line (see Appendix Section 7.6).

Depth/Spacing

Ideally mount your lights at similar depth levels to ensure matching colour consistency through the water. Deeper lights will look duller and possibly differ in colour compared to shallower mounted units.

Spacing / Install Depth	E6/E7 TH
Recommended Spacing	2.5-3m (8-10')
Recommended Installation depth (From the light waterline)	300mm (12")

Hull Thickness

Maximum hull thickness – 80mm (3.15")

Hole Cut Out

Hole Cut out size - 25mm (1") / With Isolation Kit 32mm (1.25")

Overall Dimensions

See overall dimension schematic – See Appendix (Section 7)

4 Installation

4.1 INSTALLING THE LIGHT FIXTURE



Additional items required not supplied by OceanLED:

- Marine sealant - 3M 4200 or equivalent
- Cable ties
- Waterproof Cable Connectors / Junction Box* (optional)
- Allen key (5mm)
- Thread lock - Loctite 243 or equivalent.

*Optional 4-Way Junction box available from OceanLED. Please contact OceanLED or your representative for further information.

OceanLED recommends dry fitting all products. Before applying sealant, please ensure the surface is clean of any dust, dirt or grease. When installing, be sure that the light fits the area and secures to the hull using the appropriate hardware before applying any sealant.

When applying sealant to the light fixture, use OceanLED packaging material such as the light cardboard box when placing the light on the ground face down to prevent lens damage.

Never use power tools to secure your lights; hand tighten only.

Installation Overview:

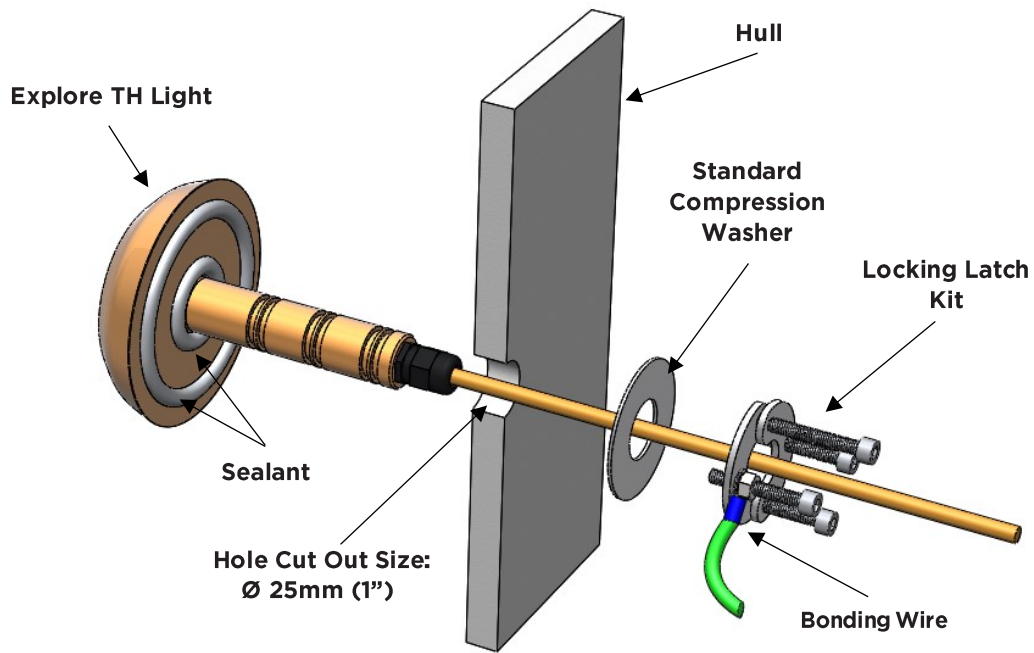

Exploded view of the assembly

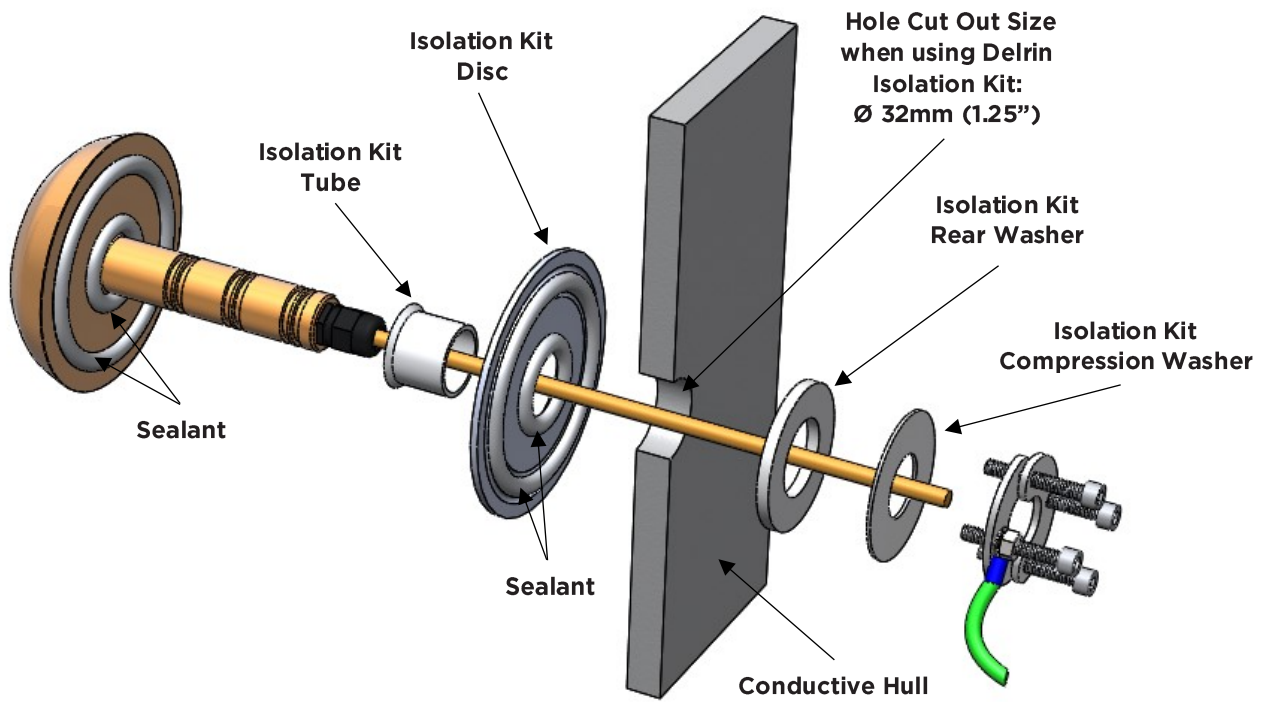

Exploded view of the assembly with the Delrin Isolation Kit

Installation (Once hull preparation is complete)

1. Test light(s) before fitting.
2. If using a Delrin Isolation Kit, fit the isolation kit tube inside the Isolation kit disc (chamfered sides together) and apply marine sealant on the back of the disc to seal between the disc/tube and the hull. Insert the part into the drilled hole in the hull. Press the disc into the hull to spread the sealant around to ensure good adhesion.

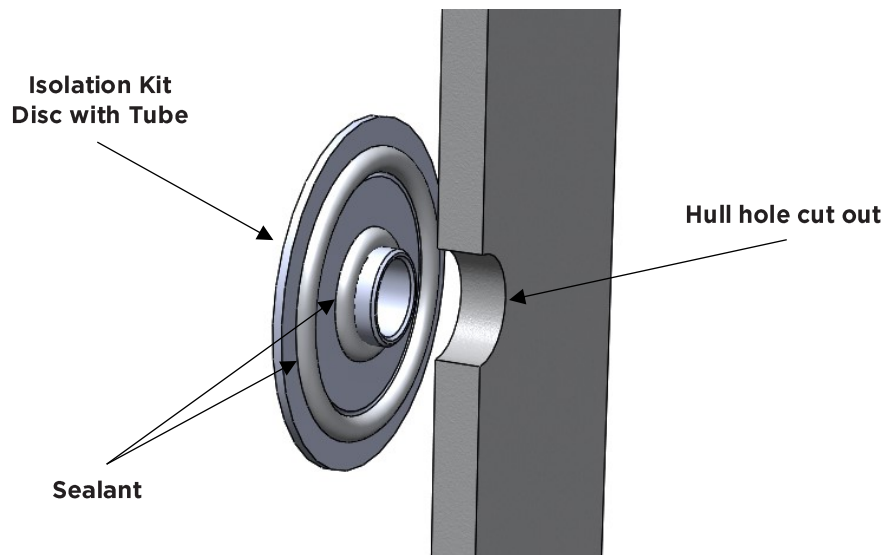

3. Apply sealant to the back perimeter of the light body and around flange to ensure a complete unbroken seal around the light.

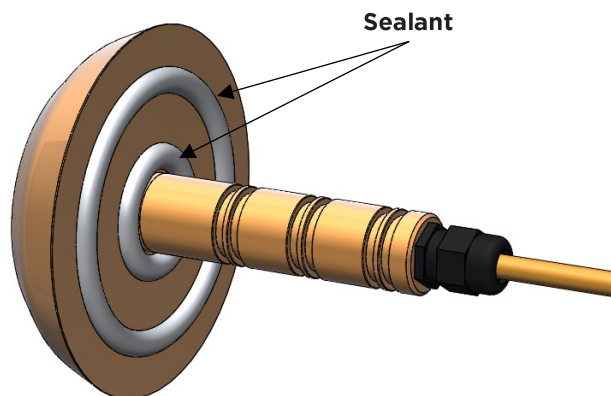

Make sure sealant fills in the recess groove on the reverse of the light head.

4. To guarantee correct light orientation ensure the OceanLED logo on the reflector is in the correct orientation before inserting it in the hull (typically the logo is located at the top). For Explore E7 TH angled fitment, ensure the light angle is correct for the location before fitting the light. If available, follow the OceanLED Light Placement Chart (LPC) where the required angle for each light position around the hull will be detailed. For further details, see the diagram in the Appendix (Section 7.6).

5. Insert the light body into the hull, feeding the stem through first and seat into place. Press the light hard into the hull and twist slightly to spread the sealant around behind the light to ensure good adhesion.

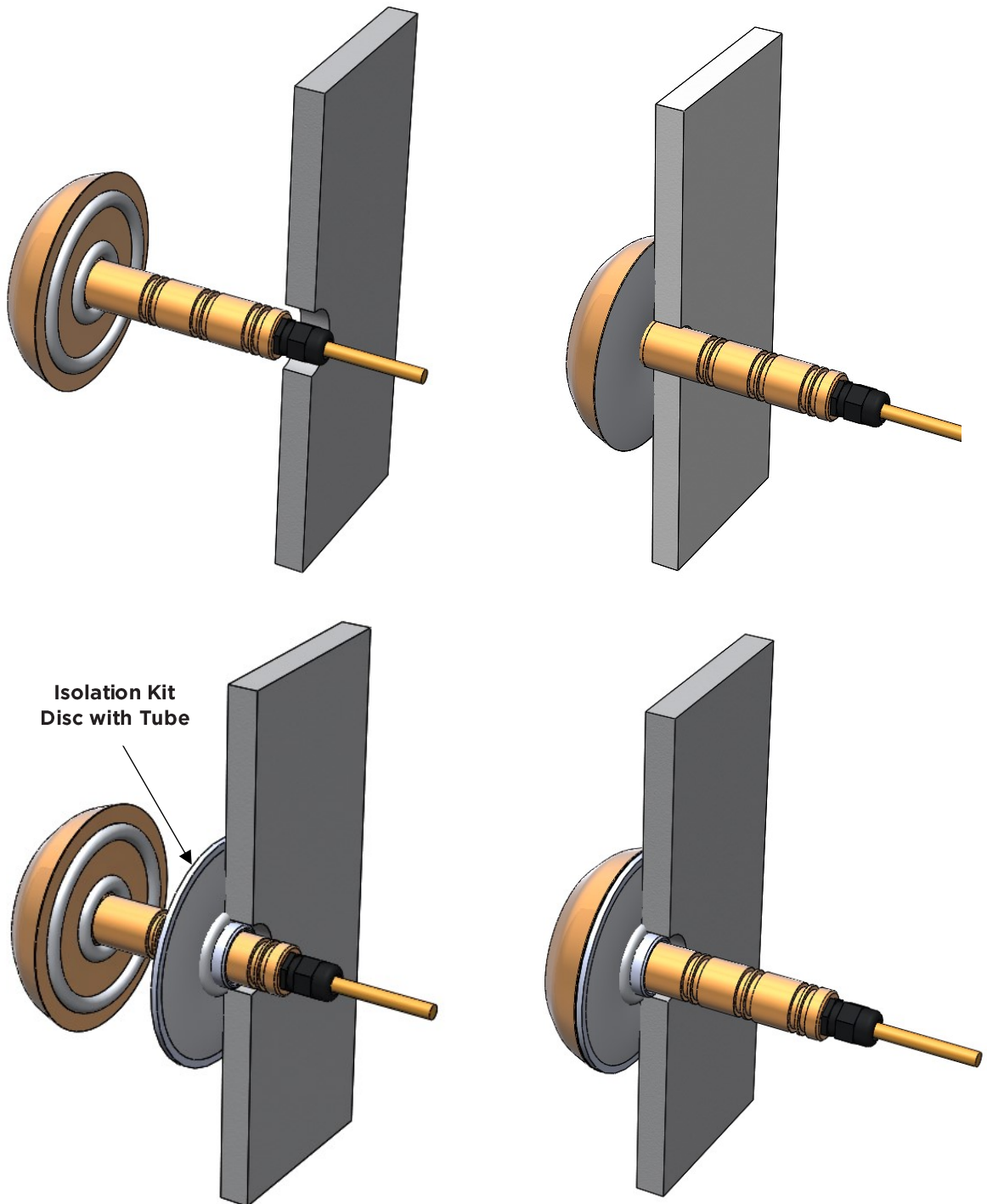

**Installation With Delrin Isolation Kit*



This process is made much easier if a second person is inside the hull to receive the light and install the clamping equipment whilst supporting the light from the outside. Breakages due to lights falling out of the hull are NOT covered under warranty and can cause serious bodily injury as can any falling object.

6. If using a Delrin Isolation Kit, insert the isolation kit rear washer over the stem and locate it flush with the hull.
7. Insert the stainless-steel compression washer over the stem at the back.

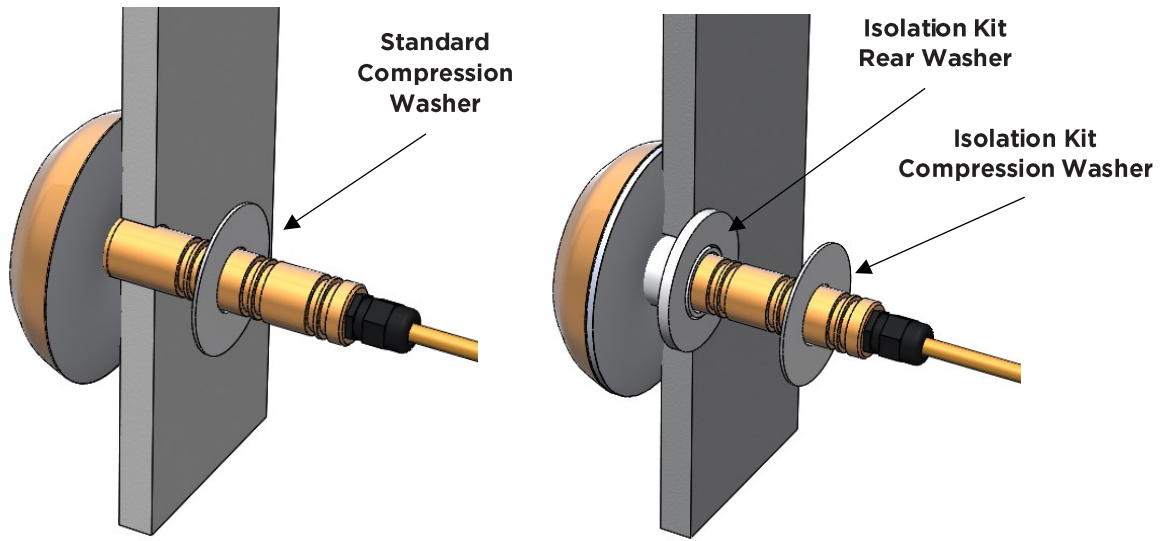

**Installation With Delrin Isolation Kit*

The stainless-steel compression washer does not need to be flat to the hull, the washer can compensate a slightly uneven surface.

8. Place the two locking latches together to form a circle, ensuring you pair 1 threaded and 1 non-threaded hole together. Fix the latches together using one of the bolts provided so that the bolt slightly extends from the other side of the latch. Pre-assemble the bonding attachment parts in the following order: M4 bolt, M4 nut, M4 shakeproof washer, bonding eyelet. Position the bonding eyelet, nut and shakeproof washer close to the M4 bolt head, while allowing the bonding eyelet to rotate on the bolt and fit the bolt assembly into the middle thread hole of the locking latch. Fit the third bolt to the middle threaded hole of the second locking latch and fit the fourth bolt to the remaining hole but do not join with the second latch yet.

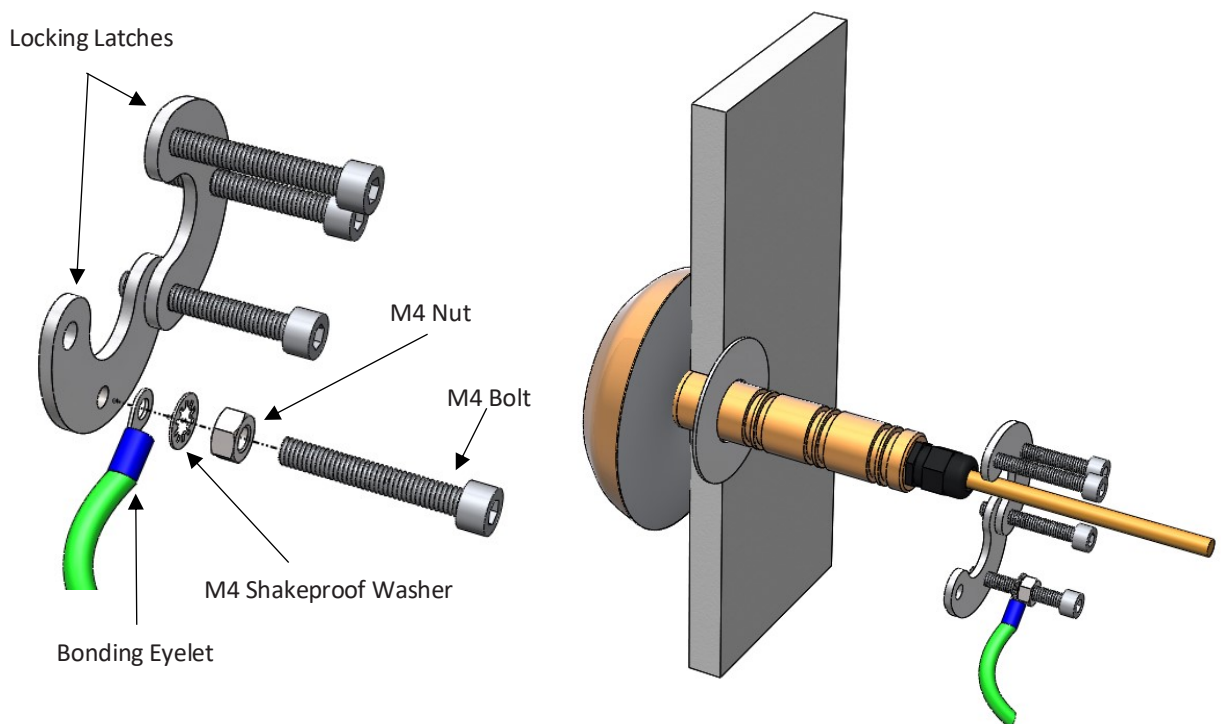

9. Locate the latches into the appropriate grooves (depending on hull thickness) on outside of the stem so that the end of the bolt is close to the washer. Fix the two latches together and screw down the joining bolt to the same position as the others.

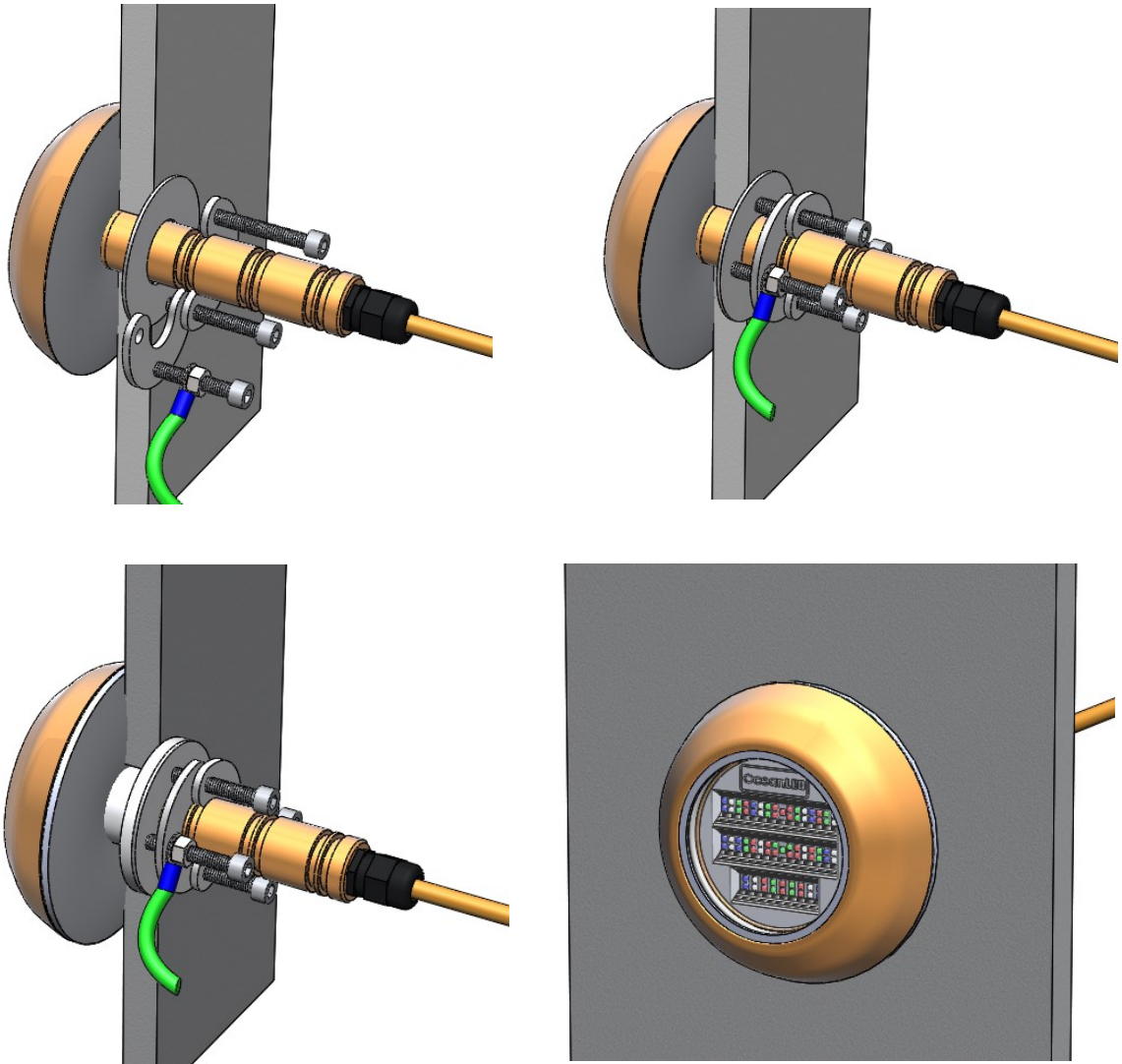

**Installation With Delrin Isolation Kit*

10. Tighten the locking bolts using a 5mm Allen key, applying thread lock at point of thread contact with locking latches. Torque to 2Nm. **DO NOT** over-tighten locking bolts.
11. Lock the bonding wire eyelet in place with the nut and shakeproof washer. Tighten the locking nut using a 10mm spanner.
12. Once you are satisfied that the unit is fully tightened, you will notice that sealant has squeezed out from around the perimeter of the light. Using a thinner or cleaner, apply to cloth and wipe off excess sealant to leave a clean seal. **AVOID CONTACT WITH LENS**. If you do not see sealant squeeze out from the body, you have not used enough sealant or tightened the unit enough to the hull. Carefully examine the installation to make sure the sealant you have installed on the unit is fully watertight. If in doubt, remove light, re-apply sealant and re-install.
13. Connect the light bonding wire to the vessel's cathodic protection system.

BONDING: The light **MUST** be attached to the vessels bonding / cathodic protection system. Once fitted it is mandatory to check that there is full continuity between the vessel's cathodic protection system and the aluminium bronze front bezel. Please see the bonding check schematic in the Appendix (Section 7.2).

4.2 INSTALLATION OF THE DRIVER WITH THE AC POWER KIT



Additional items required not supplied by OceanLED:

- Screws to secure the Explore AC Power Pack and DC Driver
- Waterproof connectors/ Junction Box
- Sufficient cable to connect the Explore AC Power Pack to power source.
- Suitable fuse / breaker(s)



Always consult a qualified electrician when connecting OceanLED light fixtures.

Never use power tools to secure the DC Driver or Explore AC Power Pack: hand tighten only.

When connecting light units, please note that all OceanLED lights will operate within a specific voltage range. Please check the electrical information to ensure cable gauge, fuse and breakers size follow the recommendations.

Always mount the Explore DC Driver and AC Power Pack in a dry location, it should not sit in standing water at any time.

Connecting the DC Driver

1. Find the appropriate location for the driver bearing in mind that the distance from the light is predetermined by the 1.8m long light cable and cannot be extended. Ensure chosen location is near enough to connect light cable without applying undue stress.
2. Fix Explore DC Driver into required position and secure with four screws.
3. Connect the plug from the light into the 10 pin port on the driver.
4. Repeat the process for the remaining drivers.
5. Connect the drivers in chain with the Control Link Cable (see the connection diagram on the next page).
6. Connect the Terminator in the last driver in chain.

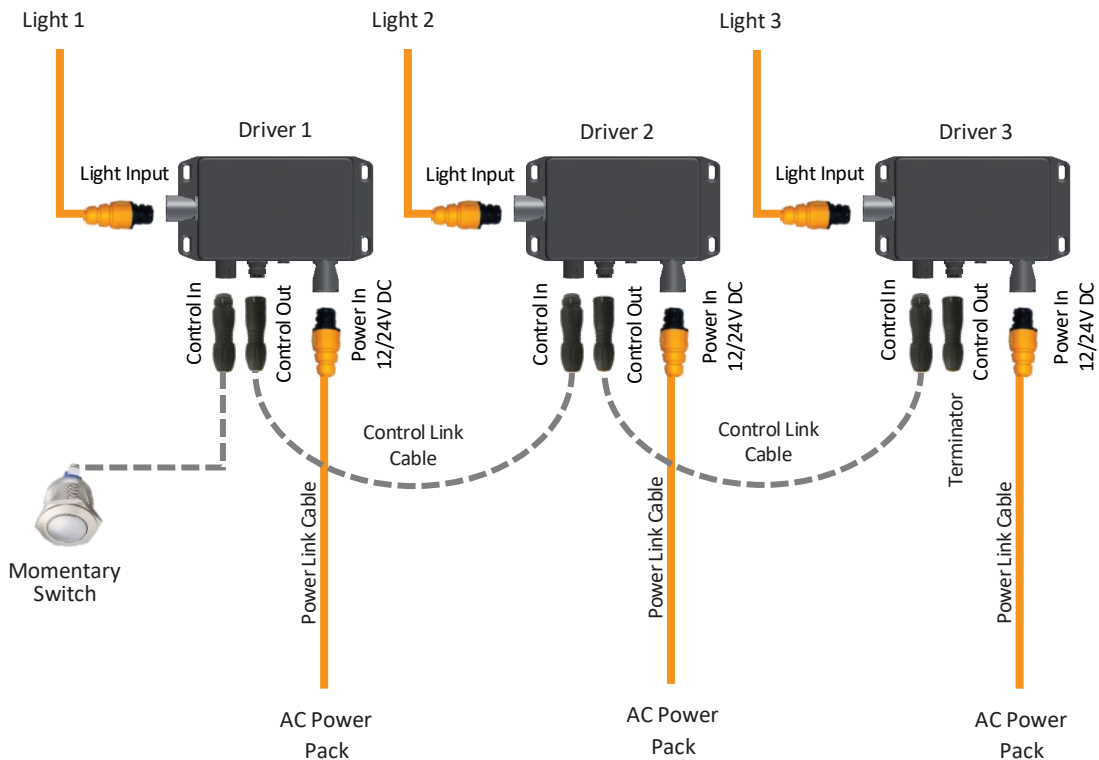

Explore DC Driver Connection Diagram Example with Switch Control (with the AC Power Kit)

Connecting AC Power Pack

 The 3-core input is for power (Brown=Live; Blue=Neutral; Green/Yellow=Earth) and the two pin Deutsch Connector is for the driver.

1. Depending on the model and number of lights installed, you will need to pull the correct sized power cable from the AC Power (breaker/fuse panel) to the Explore AC Power Pack locations. Ensure the correct sized tinned marine grade cable is used to avoid voltage drop issues.
2. Fix Explore AC Power Pack into required position. The maximum distance between the AC Power Pack and the DC Driver is predetermined by the length of the Power Link Cable (1.5m). Ensure chosen Explore AC Power Pack location is near enough to connect the Power Link Cable to the DC Driver cable without applying undue stress.

 **Never leave the bare cables unprotected. Take care to not leave the bare wire ends in bilge water before making the waterproof connections. Water deposits in the connectors and cables will cause corrosion. Over time water can also work its way into the unit along the inside of the cable due to capillary action causing the light to fail. This will NOT be covered under warranty.**

3. Connect the Deutsch connector from the AC Power Pack to the DC Driver using the Power Link Cable.
4. Connect the Explore AC Power Pack to the AC Power. Ensure the size fuse/breaker, cable and connector have the correct specification and are watertight. Make sure any heatshrink used completely encapsulates the outer wire sheath (the use of glue-lined heatshrink is highly recommended to ensure water tightness).

 **Corrosion of wire and/or water ingress into the light unit via cable is NOT covered under warranty.**

5. Secure cables ensuring where the cable exits the light it is not under undue stress.
6. Install and connect the lighting control system, please see chapter 4.4 for the control system installation. Finish and test the light units **BEFORE** the vessel goes into the water. **Do not operate lights out of water for a period longer than 5 minutes followed by an OFF period of at least 1 hour. Exceeding this may cause damage to the light unit.**

Example of the AC Installation (i.e. with the AC Power Kit)

Explore TH Lighting System Control Options

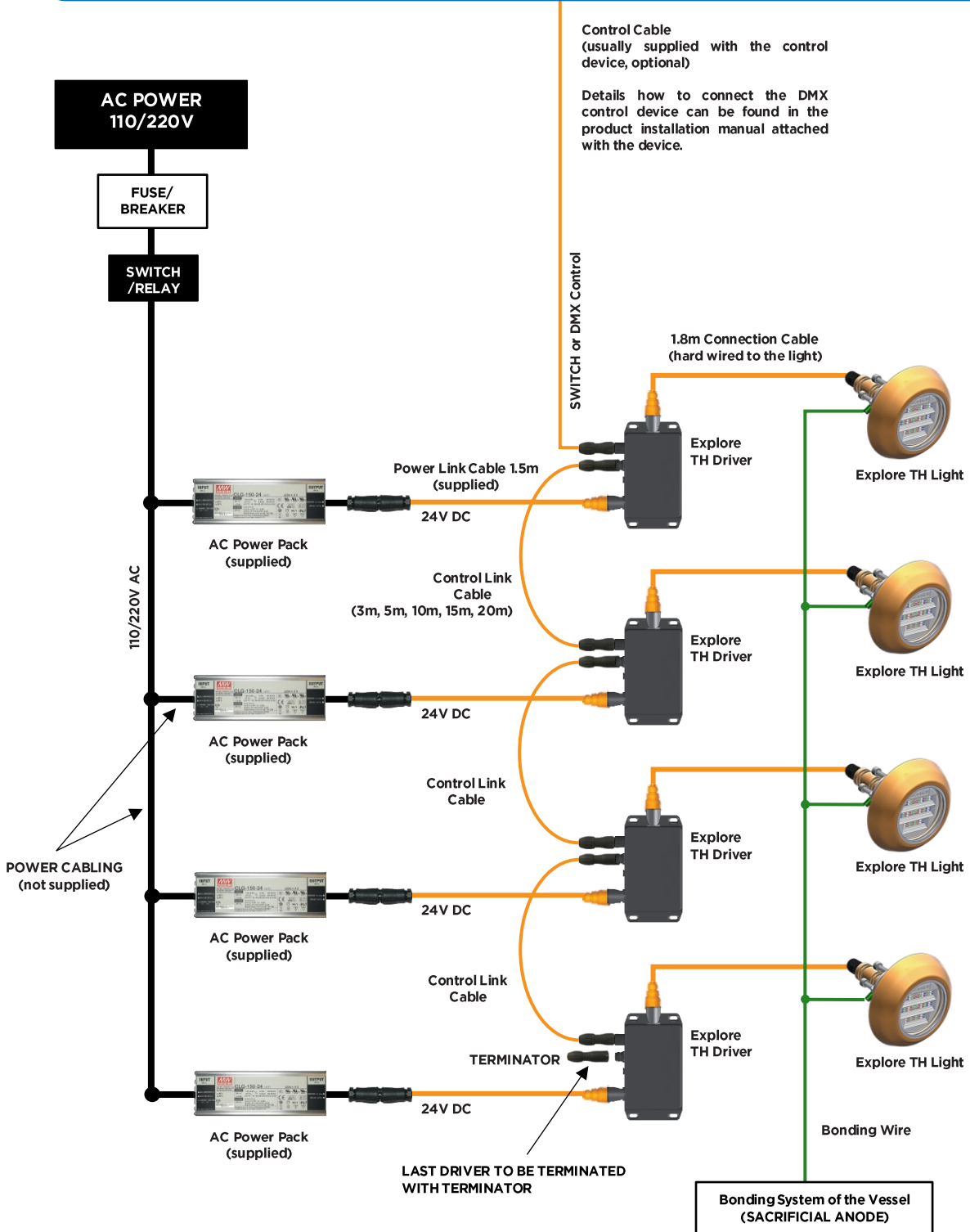

4.3 INSTALLATION OF THE DRIVER WITH THE DC POWER KIT

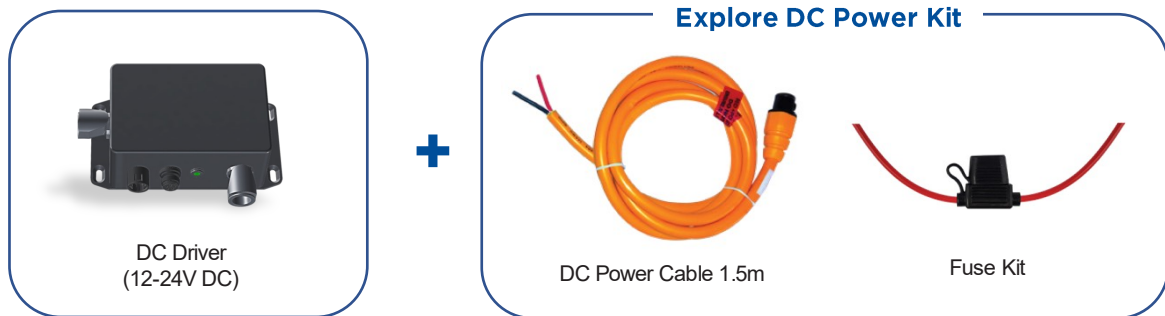

Additional items required not supplied by OceanLED:

- Screws to secure the DC Driver
- Waterproof connectors/ Junction Box* (optional)
- Sufficient cable to run connections to power source.
- Suitable fuse / breaker(s)

*Optional 4-Way Junction box available from OceanLED. Please contact OceanLED or your representative for further information.



Always consult a qualified electrician when connecting OceanLED light fixtures.

When connecting light units, please note that all OceanLED lights will operate within a specific voltage range. Please check the electrical information to ensure cable gauge follow the recommendations.

Never leave the bare cables unprotected. Take care to not leave the bare wire ends in bilge water before making the waterproof connections. Water deposits in the connectors and cables will cause corrosion. Over time water can also work its way into the unit along the inside of the cable due to capillary action causing the light to fail. This will NOT be covered under warranty.

Always mount the Explore DC Driver in a dry location, it should not sit in standing water at any time.



For complete instructions on DC connections, please refer to ABYC codes of practice and other applicable codes and ordinances for DC connections.

Where multiple lights are fitted, and especially on 12V systems, it is advised to use a relay system to supply the switched power to the lights, to reduce load on the switch and voltage drops caused by long cable runs to the switch location.

Connecting the DC Driver

1. Find the appropriate location for the driver bearing in mind that the distance from the light is predetermined by the 1.8m long light cable and cannot be extended. Ensure chosen location is near enough to connect light cable without applying undue stress.
2. Fix Explore DC Driver into required position, using four mounting holes secure the driver with the four screws.
3. Connect the plug from the light into the 10 pin port on the driver.
4. Repeat the process for the remaining drivers.
5. Connect the drivers in chain with the Control Link Cable (see the connection diagram on the next page).
6. Connect the Terminator in the last driver in chain.

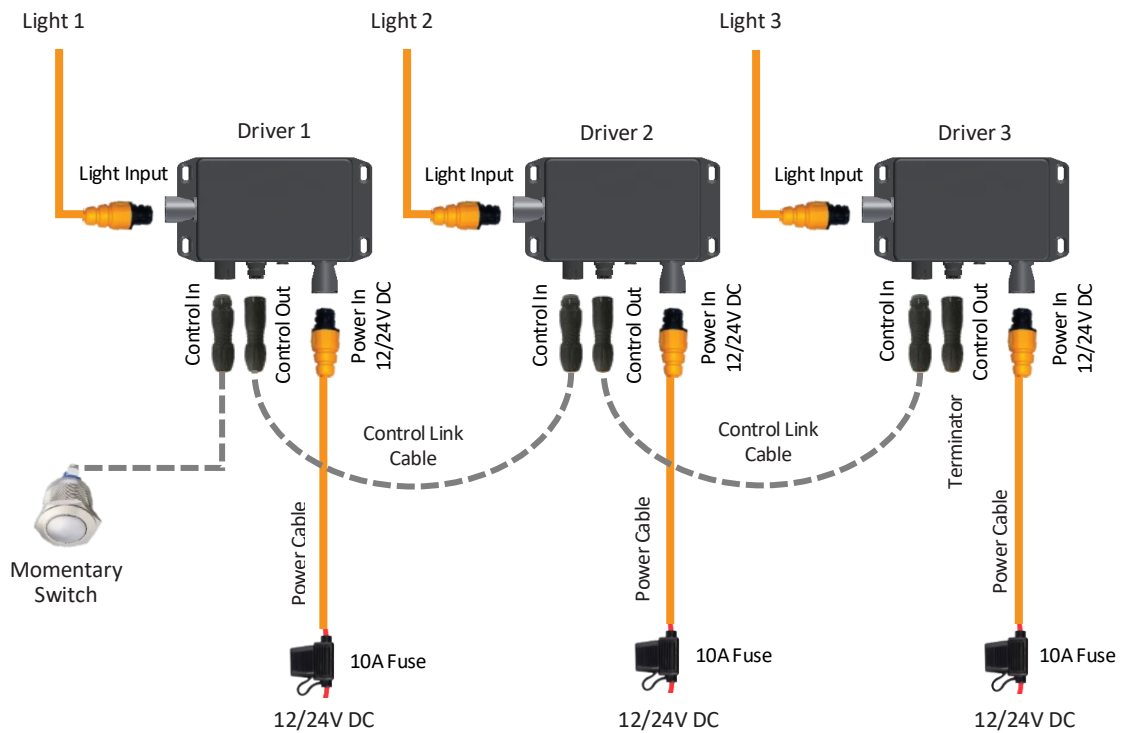

Explore DC Driver Connection Diagram with Switch Control (with the DC Power Kit)

Connecting the DC Power Kit

1. It is imperative that either the OceanLED supplied fuse is fitted to the power circuit of each light or a suitable protection device is used to protect the cable/light unit. It is important to also ensure the polarity is correct. Failure to do so will void the warranty of the unit. It is recommended to use our 4-way fused junction box. See the table in Section 2 for power consumption and recommended fuse values.
2. Using waterproof butt splices or IP66 waterproof junction boxes, make the connections at either end of the system to attach the lights to the DC system. (Red wire = +12/24V DC, Black wire = GND). Make sure any heatshrink used completely encapsulates the outer wire sheath (the use of glue-lined heatshrink is highly recommended to ensure water tightness).

! Corrosion of wire and/or water ingress into the light unit via cable is NOT covered under warranty.

3. Secure cables ensuring where the cable exits the light it is not under undue stress.
4. Install and connect the lighting control system, please see chapter 4.4 for the control system installation.
5. Finish and test the light units **BEFORE** the vessel goes into the water.

! Never install a new light fixture then leave the vessel in the water unchecked for several days.

Example of the DC Installation (i.e. with the DC Power Kit)

Explore TH Lighting System Control Options

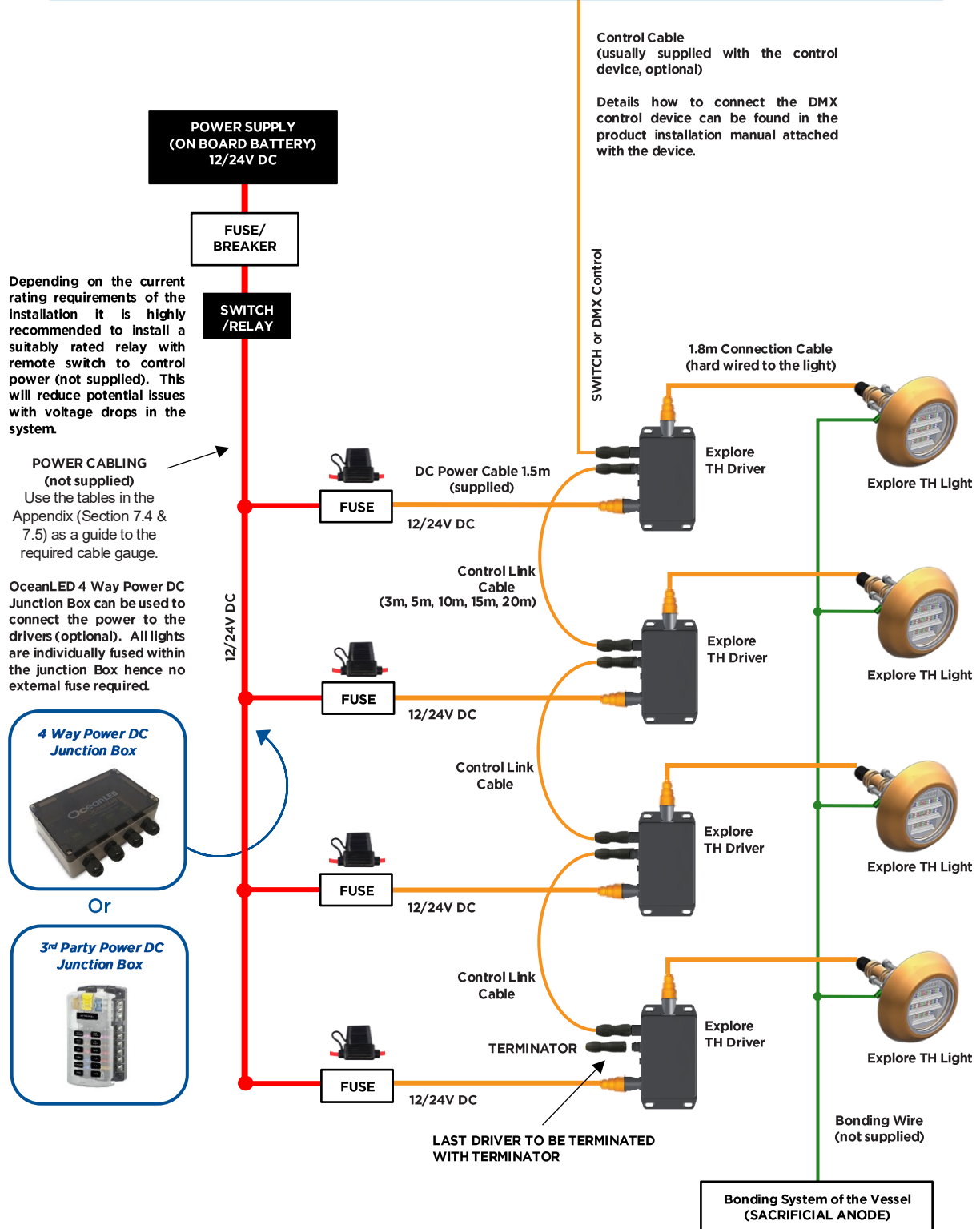

4.4 CONTROL SYSTEM INSTALLATION

Switch Control

Additional items required not supplied by OceanLED:

- Push switch (Normally open, momentary type).



To use Switch Control, the Explore Control Input Cable and Terminator Kit is required.

To connect the lights to enable control of all lights using a single switch, Explore Control Link Cables must be used. The quantity of Control Link Cables required per installation is equal to the number of lights minus 1 (Example: If 10 lights are used, 9 control link cables are required). Please consult the Explore TH Light Choice Diagram in the Appendix (Section 7.3) for details.



Ensure power is disconnected before attempting to connect or solder any wire.

1. Connect one contact of the switch to the red wire of the Explore Input Control Cable. Connect the black (Ground), yellow (DMX +) and brown (DMX -) wires together and connect to the other contact of the switch:

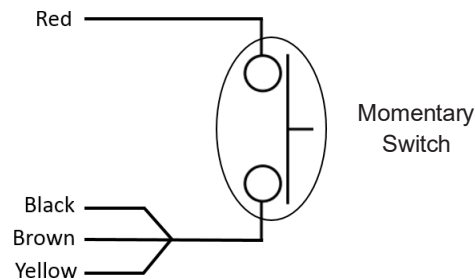

2. Plug the Switch cable to the 'Control In' Connector of the first driver.
3. Using the Control Link Cable, connect the 'Control Out' of the first driver to 'Control In' of the next driver. Repeat until all the drivers are connected. Check the diagram below for clarification.
4. Plug the Explore Terminator to the 'Control Out' of the last driver.
5. Test the light units **BEFORE** the vessel goes into the water.

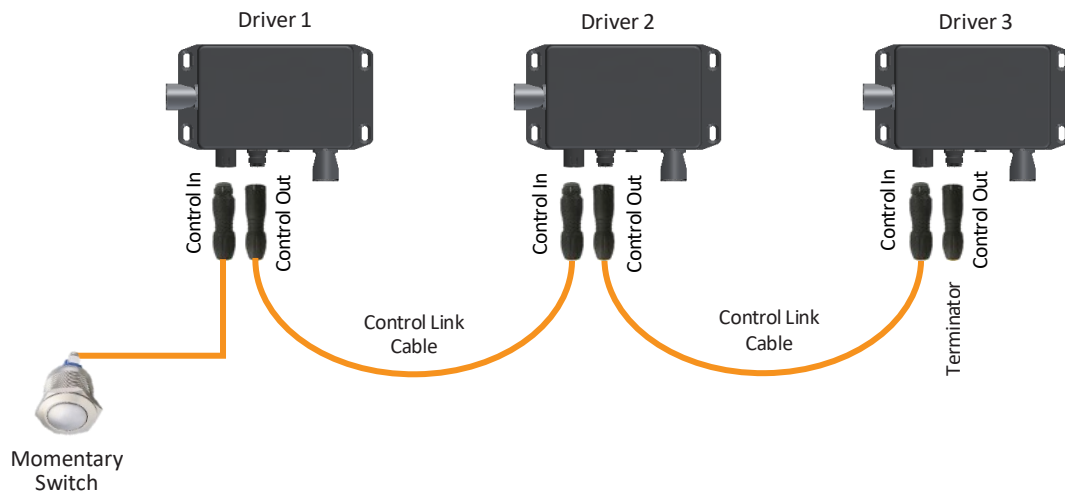

Control Switch Connection Diagram Example

OceanLED DMX Control Kits

To use OceanLED DMX Control, one of our DMX kits must be purchased from OceanLED. Please consult the Explore E6/E7 TH Light Choice Diagram for details (see Chapter 7.3).

To enable the DMX Control of all lights, Explore E6 & E7 Control Link Cables must be used. The quantity of Control Link Cables required per installation is equal to the number of lights minus 1 (Example: If 10 lights are used, 9 control link cables are required).

Ensure power is disconnected before attempting to connect or solder any wire.

Please consult the manual for the purchased DMX Control Kit for more information on installation and operation.

3rd Party DMX Control

Additional items required not supplied by OceanLED:

- External DMX Control System

To use a 3rd Party DMX Control, the Explore Control Input Cable and Terminator Kit is required.

To enable the DMX Control of all lights, Explore Control Link Cables must be used. The quantity of Control Link Cables required per installation is equal to the number of lights minus 1 (Example: If 10 lights are used, 9 control link cables are required).

Ensure power is disconnected before attempting to connect or solder any wire.

1. Connect the DMX Control unit to the Explore Control Input Cable following the wiring connections below:

Cable colour	Signal
Black	GND
Yellow	DMX +
Brown	DMX -
Red	Not used

2. Plug the Explore Control Input Cable to the 'Control In' Connector of the first light.
3. Using the Control Link Cable, connect the 'Control Out' of the first light to 'Control In' of the next light. Repeat until all the lights are connected. Check the diagram on the next page for clarification.
4. Plug the Terminator into the 'Control Out' of the last light.

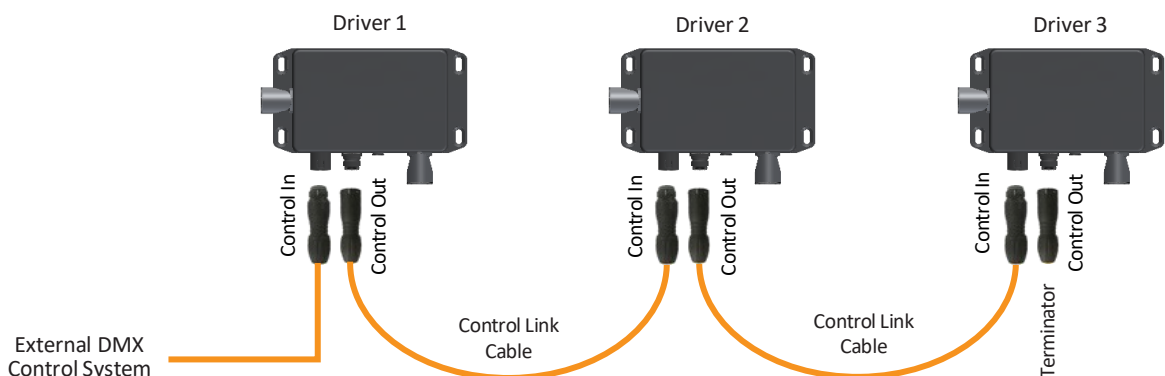

External DMX Control Connection Diagram Example

DMX Addressing

- OceanLED Explore E6/E7 TH lights use DMX-512 standard for communication.
- As default the base address of the lights is set to DMX address 1.
The default base address of the lights can be changed if required. This can either be done using a third party RDM (Remote Device Management) controller, or by using the OceanLED Explore Configuration Tool.
- Dual colour lights use two DMX addresses, the first for the Blue channel, the second for the White channel (i.e., Address 1 is the Blue Channel, address 2 is White Channel).
- Colours lights use four DMX channels – the first for the Red channel, second for the Green Channel, third for the Blue channel, and the fourth for the White channel.

 **The DMX standard recommends a maximum of 32 devices to be connected in one chain, and a maximum network length of 300m. If installation requires more lights than this, or a longer network length then please contact OceanLED for advice.**

--- Third Party RDM controller ---

Third Party RDM (Remote Device Management) software/ controller permits a controlling device to discover and then configure, monitor, and manage lighting devices connected through a DMX512 network.



To use a 3rd Party RDM Controller, the Explore Control Input Cable and Terminator Kit is required (this is the same kit as used for 3rd Party DMX Control). Please contact your OceanLED representative for more information.

Additional items required not supplied by OceanLED:

- Third party RDM-DMX512 Controller
- Third party RDM Software Manager

--- OceanLED Explore Configuration Tool ---

The Explore Configuration Tool is a USB interface to allow remote configuration of the Explore E6 & E7 lights using a Windows PC. It allows the setting of base DMX address, change of operating modes and readback of stored parameters.

Communication with the lights is achieved using the Remote Device Management (RDM) protocol over the existing DMX network.



Explore Configuration Tool Kit can be purchased from OceanLED (P/N: 019909). The Tool Kit contains Explore Configuration software, USB Connection Cable and detailed instruction manual. Please contact your OceanLED representative for more information.

General info:

Items required:

- PC/Laptop (Win7,8,10 only) with free USB 2.0 port and with Explore Configuration app installed
- Control cable
- Explore-Series Lights

Light Configurator Features:

- Set unique light name/device label
- Change DMX Start Address
- Change Control Mode (Switch, DMX or Switch/DMX)
- Enable/Disable Strobe Mode (Switch version)
- Change Fix Colour (Colour palette for Colours Light)

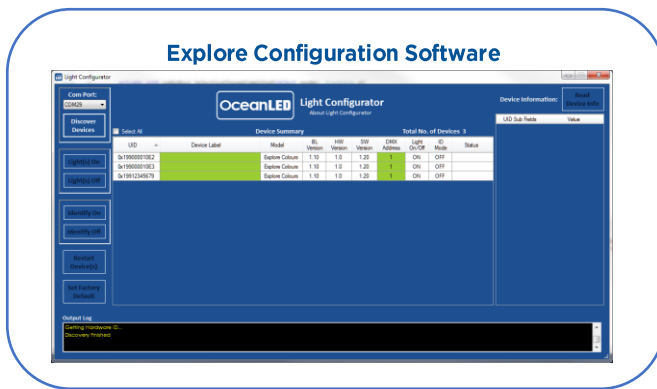

PC / Laptop



USB Control Cable connects lighting system with the PC.

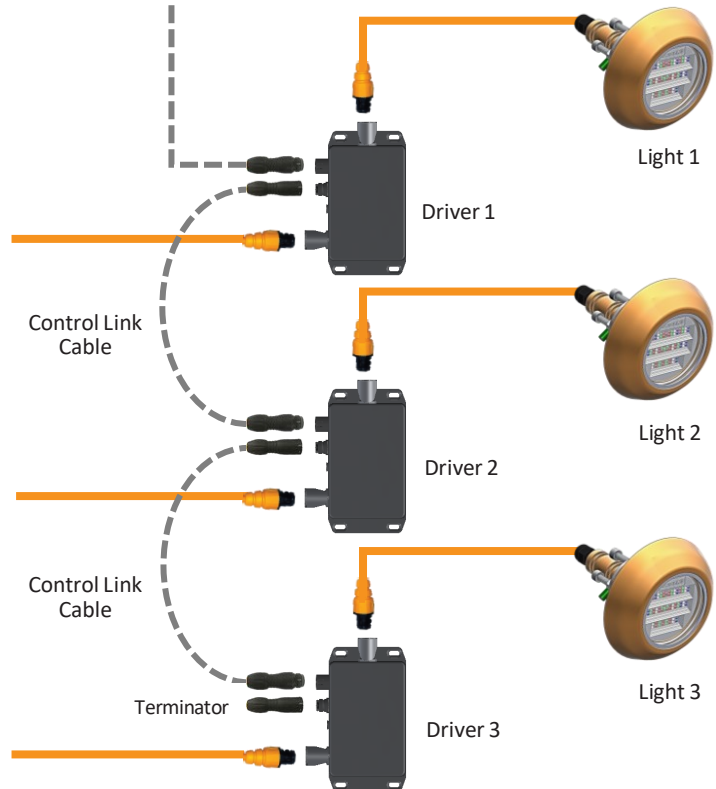

Explore TH Configuration Tool System Connection Outline

4.5 FINALISING THE INSTALLATION

The Explore TH body is constructed from corrosion resistant Aluminium Bronze and does not require further protection. The glass is pre-coated with a specialized Tritonium® coating which makes the surface of the glass lens a non-stick layer. Do not apply any additional coatings, such as foul-release products, to the front of the lens without consulting OceanLED. Failure to do so will void your warranty.

OceanLED does not recommend that bottom paint or any type of anti-fouling agent is applied to the front of the light, as damage may occur due to chemical incompatibility. If bottom painting of the bezel is deemed essential, then an area of at least 5mm should be left uncoated around the glass lens:

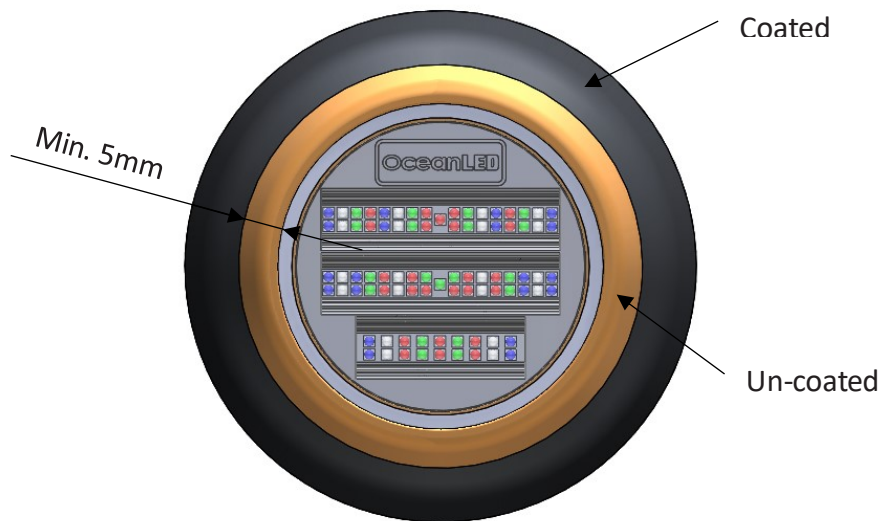

The protective lens sticker should be removed once all work on the vessel is complete.

! Do not coat the light's glass/lens with any product, including but not limited to clear antifouling paints or similar, without consulting OceanLED for advice. Failure to do so will void your warranty.

Do not use any un-authorized cleaning products to remove excess paint or antifoul off the glass or within 5mm of the glass. OceanLED recommends using Isopropyl Alcohol (IPA) only.

4.6 TEST YOUR INSTALLATION

Always test the lights **BEFORE** the vessel goes back into the water. At this final stage make sure all of the system is operational. If you have any issues, please contact your local OceanLED representative.

! Never install a new light fixture then leave the vessel in the water unchecked for several days. Never leave lights ON out of water for longer than 5 minutes followed by an off period of 1 hour.

When the vessel is placed in the water, immediately check for leaks. Note that very small leaks may not be readily observed. It is best not to leave the vessel in the water for more than 3 hours before checking it again. If there is a small leak, there may be considerable bilge water accumulation after 24 hours. If a leak is observed, you must **TAKE ACTION IMMEDIATELY** to prevent damage.

5 Operation / Maintenance

5.1 OPERATION

Switch Control

The Switch Control mode allows the user to switch between colours and strobe modes using a push switch.

The sequence for the Explore E6 & E7 TH Dual White/Blue is a closed loop as follows:

1. Solid White (*default stage after power cycling*)
2. Solid Blue
3. Fade White / Blue
4. Strobe Blue
5. Strobe White
6. Strobe White / Blue
7. 50% White and 50% Blue

After step 7 the next button press will reset the sequence back to step 1.

The sequence for the Explore E6 & E7 TH Colours DMX is a closed loop as follows:

1. Solid Chosen Colour (*default stage after power cycling – last chosen colour stored*)
2. Strobe Chosen Colour
3. Colour Cycle

If during the colour cycle (step 3), the switch is pressed again, the cycle will stop and the current colour will be stored and remain static (i.e., go back to step 1 in the sequence, with a new stored chosen colour).

DMX Control

Please refer to the purchased DMX Controller for details about how to use it. For 3rd party DMX control see section 4.4.



When receiving a DMX signal, the driver LED Indicator will turn on and off approximately once per second. Please see more info about the Indicator states in the chapter 6.1.

5.2 MAINTENANCE

Marine growth can build up quickly on the light and can reduce the light's performance in just a few weeks. To help prevent this, all OceanLED lights have been coated with a specialized Tritonium® coating which helps to prevent marine growth from adhering to the glass. Lights should be cleaned with a boat brush or similar bi-weekly, or as needed to keep the lens of the light clean.

Growth varies greatly around the world and maintenance is imperative to the proper operation and longevity of the product. If heavy fouling occurs, growth can be removed from the lens using a plastic scraper and moderate pressure under water. If cleaning the lens while the boat is out of the water, wet the lens before scraping. Never scrape or try to remove barnacles from a dry lens.



-  **Never use high pressure jet wash to clean the lens / bezel as this will damage the seals and void the warranty. Do not use harsh cleaning solvents, as they will damage the light seals and Tritonium coating.**
-  **Do not coat the light's glass/lens with any product, including but not limited to clear antifouling paints or similar, without consulting OceanLED for advice. Failure to do so will void your warranty.**
-  **If bottom painting ensure the coating is applied as instructed in the “Finalising The Installation” section. Failure to do so will invalidate your warranty.**

5.3 REPLACEMENT PARTS

The light source of this luminaire is not replaceable; when the light source reached its end of the life the whole luminaire shall be replaced.

If the external flexible cable from the back of the light is damaged, contact your local OceanLED representative to arrange for replacement (cable must only be replaced by OceanLED, service agent or a similar qualified person).

Lost, broken and worn parts can be replaced on request and can be obtained through your local OceanLED representative.

6 Troubleshooting

6.1 TROUBLESHOOTING PROBLEMS AND THEIR SOLUTIONS

The Explore TH driver have a built-in LED Indicator that will confirm that the light is working inside the designed parameters and will give information if a fault has been detected.



LED Indicator

The Indicator should be lit when light is powered and on. When receiving a DMX signal, the Indicator will turn on and off approximately once per second. If light is in Firmware/Bootloader update mode, the LED Indicator will flash rapidly approximately 3 to 4 times per second.

Should any flashes be observed outside of the time frames mentioned above, please refer to the table below.

The table below summarizes the fault codes the driver LED Indicator can show. The fault code is shown by a repeated cycle of a succession of flashes followed by an off period.

EXPLORE E6/E7-TH				
NO' OF FLASHES	DESCRIPTION OF FAULT	CHECK	CAUSE	FIX
0	Green LED OFF	Check voltage supply to the light is between 11V and 32V DC	Voltage ok. Driver is faulty.	Contact your dealer.
1	Driver board Temperature Sensor Failure	-	Driver is faulty.	Contact your dealer.
2	LED (light) board temperature sensor failure	-	Light is faulty.	Contact your dealer.
3	Power Issue – large Voltage drop on light power-up detected 10 times	Check wiring gauge. Check if power source can supply enough current.	Incorrect wiring. Inadequate power source.	Replace wiring with correct gauge. Replace power source.
4	Power supply Voltage too low	Check voltage supply to the light is between 11V and 32V DC (The light will still work between 10 and 11 volts however at reduced brightness)	Voltage is too low	Investigate reason for low voltage and fix
5	Power Supply Voltage too high	Check voltage supply to the light is between 11V and 32V DC	Voltage is too high	Investigate reason for high voltage and fix

If the light doesn't recognize the fault but the fault is still present, please check the tables on the following pages.

EXPLORE E6/E7-TH			
PROBLEM	CHECK	CAUSE	FIX
Light does not look bright	Check that there is no marine growth on the lens	Marine growth	Clean the lens as per maintenance advice
	Check voltage supply to the light is between 11V and 32V DC (The light will still work between 10 and 11 volts however at reduced brightness)	Voltage is either too high or too low	Investigate reason for high or low voltage and fix
	Check voltage supply is stable and does not fluctuate	Voltage is fluctuating	Investigate reason for voltage fluctuation and fix
	Check that the electrical connections between the driver and the supply cable have been made correctly and recommended cable gauge has been used	Poor electrical connection	Remake connection and seal joint correctly
	Confirm all LEDs are illuminated	1 or more LEDs are not working	Contact your dealer.
	Check lights to see if water is present inside the light	Water present	Contact your dealer.
	Check cable connections for corrosion	Corrosion is present	It is not advised to reuse the cable if water is present inside. Contact your dealer for a replacement. This is NOT covered by the warranty
Light has water inside	Check integrity of lens	Light will require replacing	This is not covered by the warranty - Contact your dealer for a replacement light. Only use genuine OceanLED parts
	Check connections to make sure they are not submerged in water	Light will require replacing	This is not covered by the warranty
	Check cable to make sure there is no damage to the cable	Cable will require replacing	This is not covered by the warranty. Only use genuine OceanLED parts
	Checked all factors that are above, and the light still does not work	Light faulty	Contact your dealer for a replacement light

EXPLORE E6/E7-TH			
PROBLEM	CHECK	CAUSE	FIX
Light does not light up	Check that the electrical connections between the driver and the supply cable have been made correctly	Poor electrical connection	Remake connection and seal joint correctly
	Check the cable connection between the light and the driver	Damaged light cable, damaged plug, damaged driver connector	Contact your dealer
	Check the cable gauge is sufficient for the current draw of the light/driver (measure the voltage at the light connection point)	Cable gauge insufficient resulting in voltage drop	Increase cable gauge
	Check that the driver wiring polarity is correct, red to positive and black to negative	Polarity incorrect	Change the wiring polarity and seal joint correctly. Damage to light may have occurred.
	Check that there is power supply to the driver cable connection	Poor electrical connection	Trace the cables back, checking at joints until break has been located. Then rectify the problem and seal joint correctly
	Check that the electrical connections between the driver and the circuit breaker or fuse have been made correctly	Poor electrical connection	Remake connection and seal joint correctly
	Check that the in-line fuse is intact and not blown	Replace fuse	If fuse keeps blowing, then there is a short circuit in the light system that must be traced and rectified. If no external short can be located contact your dealer
	Exchange the power cable (between driver and power supply) with one from a working unit	Light works, faulty cable	Contact your dealer for a replacement cable
	Check that the light supply circuit breaker is closed, or the fuse has not blown	Close circuit breaker / replace fuse	If breaker / fuse keeps blowing, then there is a short circuit in the light system that must be traced and rectified. If no external short can be located contact your dealer
	Driver green LED is off. Exchange the driver with one knowing to work fine	Light works, faulty driver	Contact your dealer for a replacement driver

EXPLORE E6/E7-TH													
PROBLEM	CHECK	CAUSE	FIX										
Light/s do not respond to DMX controller	Check that the DMX electrical connections between the DMX controller and the driver have been made correctly (the green LED on the driver/s should be blinking when receiving the DMX signal)	Solid Green LED DMX not connected or poor electrical connection	Remake connection										
		No Green LED, faulty driver	Contact your dealer										
	Check the link cable connection between the drivers	Damaged link cable, damaged link cable plug	Contact your dealer										
	Ensure the terminator has been fitted in the DMX OUT of the last driver. (120 Ohm resistor between DMX+ and DMX-)	Terminator not fitted	Fit terminator										
	<p>Disconnect the control cable from the output of the controller and measure the resistance between the DMX+ (yellow wire) and DMX- (brown wire). This value should be greater than 120 Ohms but not exceed 180 Ohms.</p> <table border="1" style="width: 100%; border-collapse: collapse;"> <thead> <tr> <th style="text-align: left;">Cable colour</th> <th style="text-align: left;">Signal</th> </tr> </thead> <tbody> <tr> <td>Black</td> <td>GND</td> </tr> <tr> <td>Yellow</td> <td>DMX +</td> </tr> <tr> <td>Brown</td> <td>DMX -</td> </tr> <tr> <td>Red</td> <td>Not used</td> </tr> </tbody> </table>	Cable colour	Signal	Black	GND	Yellow	DMX +	Brown	DMX -	Red	Not used	The measured value is not between 120-180 Ohms	<p>Check that all drivers are connected in chain and the last driver has terminator fitted in</p> <p>Unplug the link cable from the first driver DMX Out, unplug the terminator from the last driver. Connect the terminator into DMX Out of the first driver and measure the resistance. If resistance reading is between 120-180 Ohms move along to the next driver working your way up to the last driver to identify where there is a break in the DMX chain that could be due to broken wiring or loose connections.</p>
	Cable colour	Signal											
Black	GND												
Yellow	DMX +												
Brown	DMX -												
Red	Not used												
If all of the above is ok, most likely there is a fault with the DMX controller, ensure the controller is working fine – please refer to the controller manual troubleshooting guide for more information.	Faulty DMX Controller	Contact your dealer											

7 Appendix

7.1 OVERALL DIMENSIONS

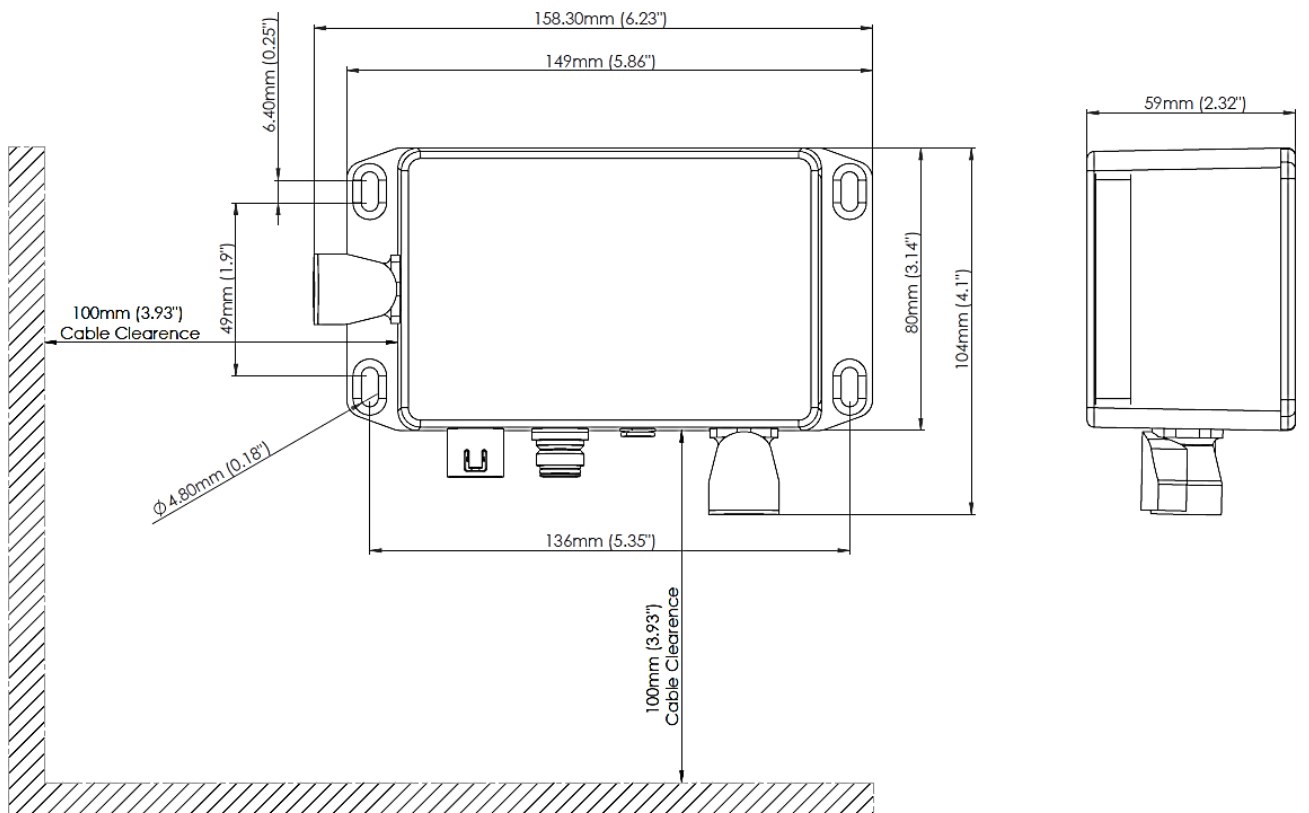
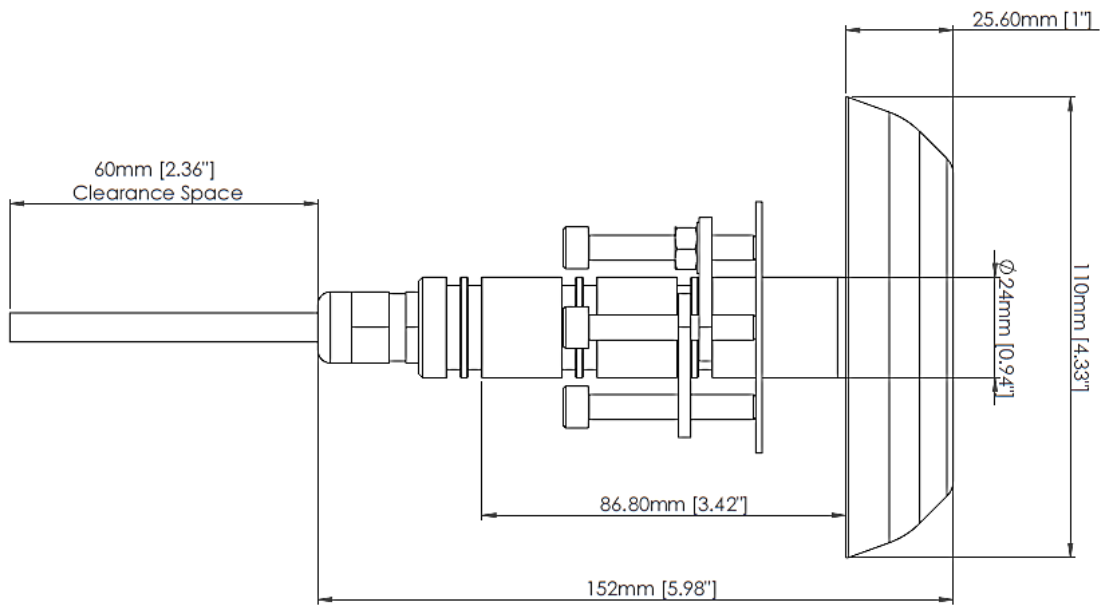

7.2 ESSENTIAL TEST

! Perform this bonding check after installation of the light and before moving the vessel back into the water.

Refer to bonding information in the installation sections in this manual. If in doubt, please contact OceanLED.

1. Connect the light assembly to the cathodic protection system as explained in **Chapter 4**.
2. Measure the electrical continuity between the front bezel and the sacrificial anode. This test should give a reading of up to 0.5Ω (Ohms). This procedure will guarantee electrical continuity between the front bezel, the stem and the sacrificial anode.

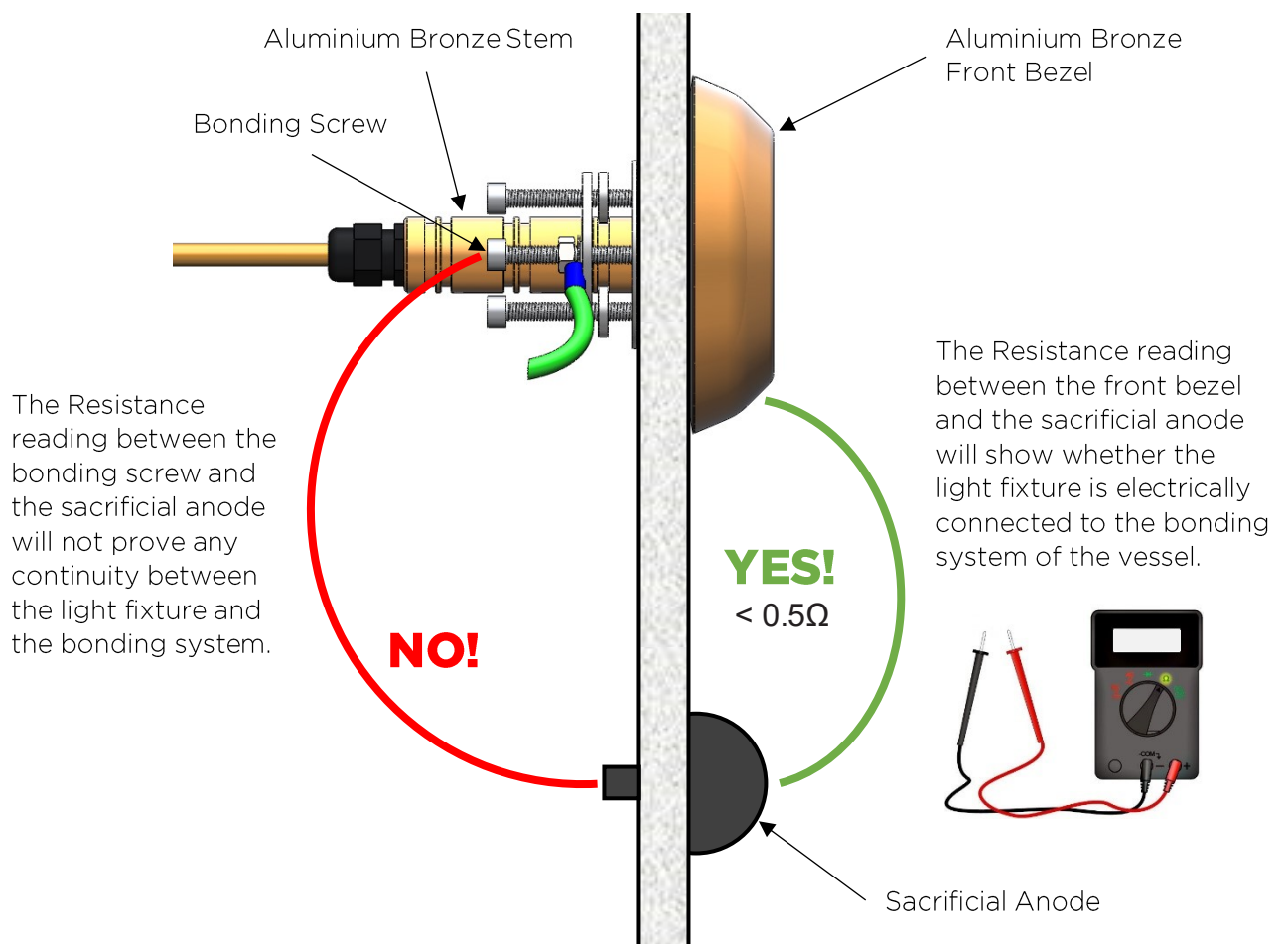

If you have any questions regarding the above, please contact OceanLED:

+44 (0) 1455 637505 or info@oceanled.com

7.3 LIGHT SETUP

The Explore Light Choice Diagram is also available at www.oceanled.com



Choose Either Dual Or Colours

Explore E6/E7 TH
(Dual)
• Light Assembly

Explore E6/E7 TH
(Colours)
• Light Assembly

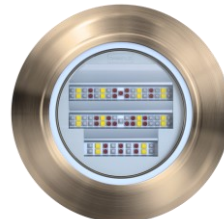
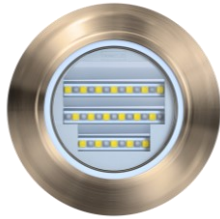

Choose Hull Angle Requirements

0° HULL ANGLE

10° HULL ANGLE

20° HULL ANGLE

#E6TH009BW
• E6 TH Dual
#E6TH009CD
• E6 TH Colours

#E7TH019BW
• E7 TH Dual
#E7TH019CD
• E7 TH Colours

#E7TH029BW
• E7 TH Dual
#E7TH029CD
• E7 TH Colours

30° HULL ANGLE

40° HULL ANGLE

50° HULL ANGLE

#E7TH039BW
• E7 TH Dual
#E7TH039CD
• E7 TH Colours

#E7TH049BW
• E7 TH Dual
#E7TH049CD
• E7 TH Colours

#E7TH059BW
• E7 TH Dual
#E7TH059CD
• E7 TH Colours



Choose either DC or AC Power Kits

OPTION 1

OPTION 2

#019903
DC Power Kit (1.5m)
• DC Power Cable
• Fuse Kit

#019904
AC Power Kit (1.5m)
• Power Pack
• AC Power Link Cable



Continued on the next page



Choose the method of how you control your lights
(Each Controller option comes with a 5m Control Input Cable Kit - Option 1)

OPTION 1

#012923
Switch / 3rd Party Control Input Kit

- Control Input Cable
- Terminator



OPTION 2

See OceanDMX RC Guide for options
OceanDMX RC Kit

- Remote / Receiver



OPTION 3

#013003 (Black)
#013003W (White)
OceanDMX TP (Dual)

- Touch Panel Controller
- Control Input Kit



OPTION 4

#013001 (Black)
#013001W (White)
OceanDMX TP (Colours)

- DMX Touch Controller
- Control Input Kit



OPTION 5

#013011 (Black Panel)
#013011W (White Panel)
OceanDMX WTP PLUS (Dual Colour)

- DMX WIFI Controller
- Control Input Kit



OPTION 6

#013010 (Black Panel)
#013010W (White Panel)
OceanDMX WTP PLUS (Colours)

- DMX WIFI Controller
- Control Input Kit



Select quantity of Control Link Cables based on quantity of lights
(N.B. You need 1 Link Cable less than the number of lights fitted)

OPTION 1

#012924
Control Link Cable (3m)
Select the quantity required (N.B. 1 cable less than No. of lights)

OPTION 2

#012925
Control Link Cable (5m)
Select the quantity required (N.B. 1 cable less than No. of lights)

OPTION 3

#012926
Control Link Cable (10m)
Select the quantity required (N.B. 1 cable less than No. of lights)

OPTION 4

#012927
Control Link Cable (15m)
Select the quantity required (N.B. 1 cable less than No. of lights)

OPTION 5

#012928
Control Link Cable (20m)
Select the quantity required (N.B. 1 cable less than No. of lights)



7.4 CABLE GAUGE CHART 12V

Supply & Return Cable Conductor Size Chart 3% drop for when using 12V DC supply											
Cable length (feet)*	Circuit Current										
	2 Amp	4 Amp	6 Amp	8 Amp	10 Amp	15 Amp	20 Amp	25 Amp	30 Amp	40 Amp	50 Amps
0-5	18 AWG	18 AWG	16 AWG	16 AWG	14 AWG	12 AWG	12 AWG	10 AWG	10 AWG	8 AWG	8 AWG
5-10	18 AWG	16 AWG	14 AWG	12 AWG	12 AWG	10 AWG	8 AWG	8 AWG	6 AWG	6 AWG	4 AWG
10-15	16 AWG	14 AWG	12 AWG	10 AWG	10 AWG	8 AWG	6 AWG	6 AWG	4 AWG	4 AWG	2 AWG
15-20	16 AWG	12 AWG	10 AWG	10 AWG	8 AWG	6 AWG	6 AWG	4 AWG	4 AWG	2 AWG	2 AWG
20-25	14 AWG	12 AWG	10 AWG	8 AWG	8 AWG	6 AWG	4 AWG	4 AWG	2 AWG	2 AWG	1 AWG
25-30	14 AWG	10 AWG	10 AWG	8 AWG	6 AWG	4 AWG	4 AWG	2 AWG	2 AWG	1 AWG	0 AWG
30-35	14 AWG	10 AWG	8 AWG	8 AWG	6 AWG	4 AWG	4 AWG	2 AWG	2 AWG	1 AWG	0 AWG
35-40	12 AWG	10 AWG	8 AWG	6 AWG	6 AWG	4 AWG	2 AWG	2 AWG	1 AWG	0 AWG	2/0 AWG
40-45	12 AWG	10 AWG	8 AWG	6 AWG	4 AWG	4 AWG	2 AWG	2 AWG	1 AWG	0 AWG	2/0 AWG
45-50	12 AWG	8 AWG	6 AWG	6 AWG	4 AWG	2 AWG	2 AWG	1 AWG	0 AWG	2/0 AWG	3/0 AWG
50-55	12 AWG	8 AWG	6 AWG	6 AWG	4 AWG	2 AWG	2 AWG	1 AWG	0 AWG	2/0 AWG	3/0 AWG
55-60	10 AWG	8 AWG	6 AWG	4 AWG	4 AWG	2 AWG	1 AWG	0 AWG	0 AWG	3/0 AWG	4/0 AWG
60-65	10 AWG	8 AWG	6 AWG	4 AWG	4 AWG	2 AWG	1 AWG	0 AWG	2/0 AWG	3/0 AWG	4/0 AWG
65-70	10 AWG	8 AWG	6 AWG	4 AWG	4 AWG	2 AWG	1 AWG	0 AWG	2/0 AWG	3/0 AWG	4/0 AWG
70-75	10 AWG	6 AWG	4 AWG	4 AWG	2 AWG	2 AWG	0 AWG	2/0 AWG	2/0 AWG	4/0 AWG	
75-80	10 AWG	6 AWG	4 AWG	4 AWG	2 AWG	1 AWG	0 AWG	2/0 AWG	3/0 AWG	4/0 AWG	
80-85	10 AWG	6 AWG	4 AWG	4 AWG	2 AWG	1 AWG	0 AWG	2/0 AWG	3/0 AWG	4/0 AWG	
85-90	10 AWG	6 AWG	4 AWG	4 AWG	2 AWG	1 AWG	0 AWG	2/0 AWG	3/0 AWG	4/0 AWG	
90-95	8 AWG	6 AWG	4 AWG	2 AWG	2 AWG	1 AWG	2/0 AWG	3/0 AWG	3/0 AWG		
95-100	8 AWG	6 AWG	4 AWG	2 AWG	2 AWG	0 AWG	2/0 AWG	3/0 AWG	4/0 AWG		

*One-way cable length from supply (usually battery) to load.

7.5 CABLE GAUGE CHART 24V

Supply & Return Cable Conductor Size Chart 3% drop for when using 24V DC supply											
Cable length (feet)*	Circuit Current										
	2 Amp	4 Amp	6 Amp	8 Amp	10 Amp	15 Amp	20 Amp	25 Amp	30 Amp	40 Amp	50 Amps
0-5	18 AWG	18 AWG	18 AWG	18 AWG	18 AWG	16 AWG	14 AWG	14 AWG	12 AWG	12 AWG	10 AWG
5-10	18 AWG	18 AWG	16 AWG	16 AWG	14 AWG	12 AWG	12 AWG	10 AWG	10 AWG	8 AWG	8 AWG
10-15	18 AWG	16 AWG	14 AWG	14 AWG	12 AWG	12 AWG	10 AWG	8 AWG	8 AWG	6 AWG	6 AWG
15-20	18 AWG	16 AWG	14 AWG	12 AWG	12 AWG	10 AWG	8 AWG	8 AWG	6 AWG	6 AWG	4 AWG
20-25	18 AWG	14 AWG	12 AWG	12 AWG	10 AWG	8 AWG	8 AWG	6 AWG	6 AWG	4 AWG	4 AWG
25-30	16 AWG	14 AWG	12 AWG	10 AWG	10 AWG	8 AWG	6 AWG	6 AWG	4 AWG	4 AWG	2 AWG
30-35	16 AWG	14 AWG	12 AWG	10 AWG	10 AWG	8 AWG	6 AWG	6 AWG	4 AWG	4 AWG	2 AWG
35-40	16 AWG	12 AWG	10 AWG	10 AWG	8 AWG	6 AWG	6 AWG	4 AWG	4 AWG	2 AWG	2 AWG
40-45	14 AWG	12 AWG	10 AWG	10 AWG	8 AWG	6 AWG	4 AWG	4 AWG	4 AWG	2 AWG	2 AWG
45-50	14 AWG	12 AWG	10 AWG	8 AWG	8 AWG	6 AWG	4 AWG	4 AWG	2 AWG	2 AWG	1 AWG
50-55	14 AWG	12 AWG	10 AWG	8 AWG	8 AWG	6 AWG	4 AWG	4 AWG	2 AWG	2 AWG	1 AWG
55-60	14 AWG	10 AWG	10 AWG	8 AWG	6 AWG	4 AWG	4 AWG	2 AWG	2 AWG	1 AWG	0 AWG
60-65	14 AWG	10 AWG	8 AWG	8 AWG	6 AWG	4 AWG	4 AWG	2 AWG	2 AWG	1 AWG	0 AWG
65-70	14 AWG	10 AWG	8 AWG	8 AWG	6 AWG	4 AWG	4 AWG	2 AWG	2 AWG	1 AWG	0 AWG
70-75	12 AWG	10 AWG	8 AWG	6 AWG	6 AWG	4 AWG	2 AWG	2 AWG	2 AWG	0 AWG	2/0 AWG
75-80	12 AWG	10 AWG	8 AWG	6 AWG	6 AWG	4 AWG	2 AWG	2 AWG	1 AWG	0 AWG	2/0 AWG
80-85	12 AWG	10 AWG	8 AWG	6 AWG	6 AWG	4 AWG	2 AWG	2 AWG	1 AWG	0 AWG	2/0 AWG
85-90	12 AWG	10 AWG	8 AWG	6 AWG	4 AWG	4 AWG	2 AWG	2 AWG	1 AWG	0 AWG	2/0 AWG
90-95	12 AWG	8 AWG	8 AWG	6 AWG	4 AWG	4 AWG	2 AWG	1 AWG	1 AWG	2/0 AWG	2/0 AWG
95-100	12 AWG	8 AWG	6 AWG	6 AWG	4 AWG	2 AWG	2 AWG	1 AWG	0 AWG	2/0 AWG	3/0 AWG

*One-way cable length from supply (usually battery) to load.

7.6 EXPLORE TH ANGLED BEAM DETAILS

Light body follows Hull geometry while Light Optics angle the beam in desired direction.

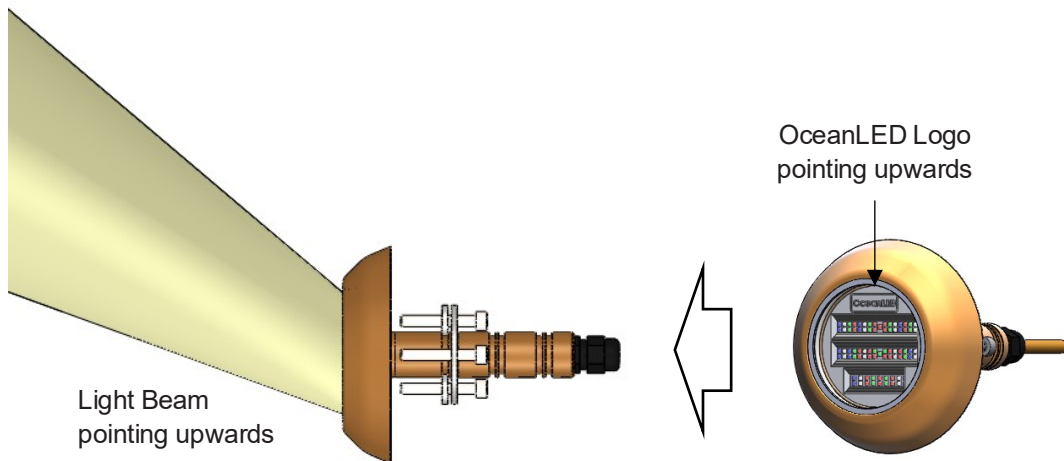
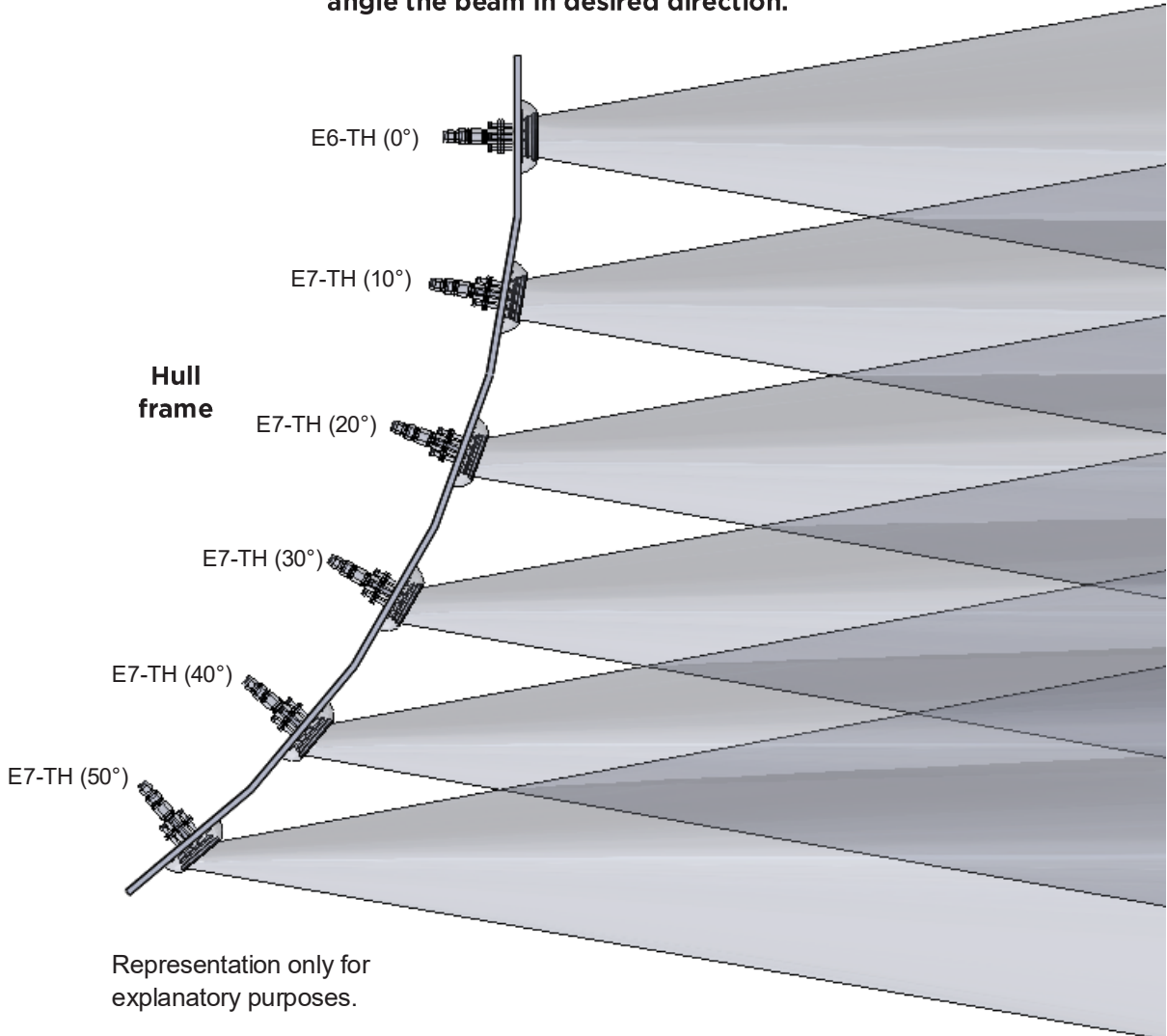

NOTE: Rotating the light by 180° on its longitudinal axis will result in a downwards orientated light beam.

7.7 EXAMPLE OF THE DC INSTALLATION OF MIXED XFM AND TH E6 & E7 LIGHTS

Explore XFM & TH Lighting System Control Options

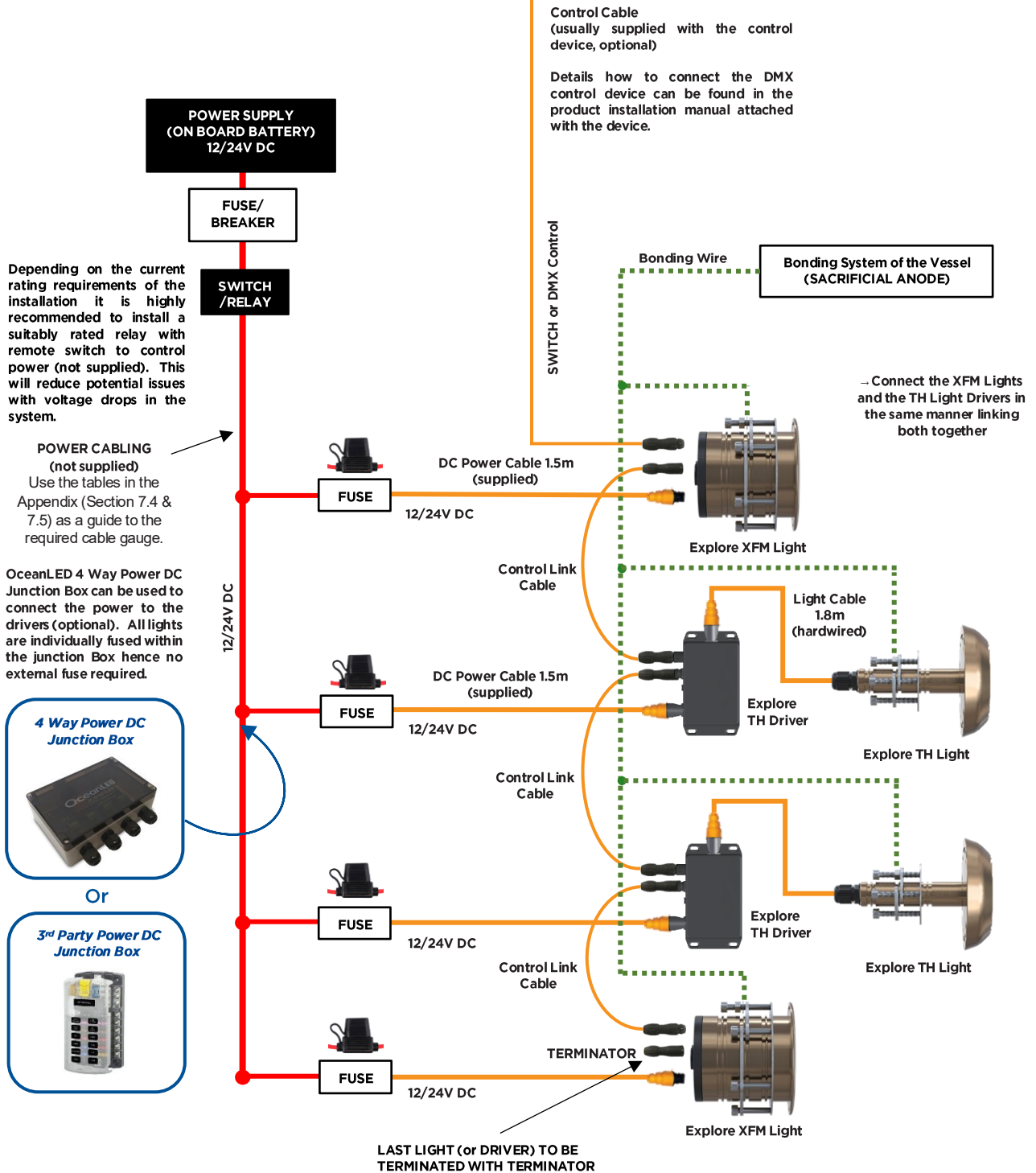
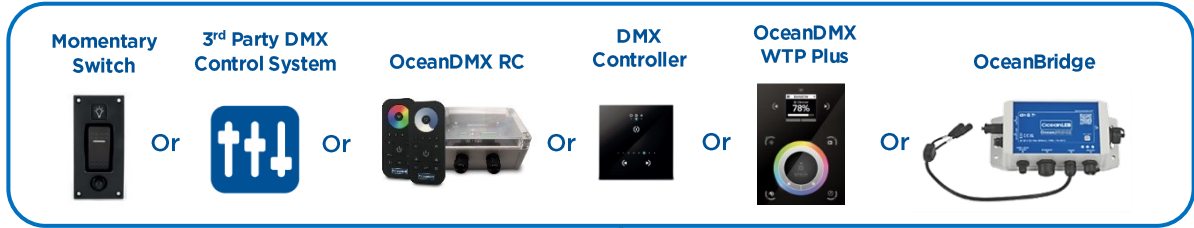

8 Warranty

Please remove this page and keep for your files.

Warranty Reminder:

- Never use a high-pressure jet wash to clean the lens or bezel, as this can damage the seals and void the warranty.
- Do not coat the light's glass/lens with any product, including but not limited to clear antifouling paints or similar, without consulting OceanLED for advice. Failure to do so will void your warranty.
- If applying bottom paint, ensure the coating is applied as instructed in the "Finalising the Installation" section. Failure to follow these instructions will void your warranty.
- Do not submerge the cable ends in water. Cables and connections exposed to underwater submersion are not covered by warranty.
- Ensure the rear of the light is kept in a dry area and not exposed to a wet environment. Failure to do so may invalidate the warranty.

Please remember that failure to follow these guidelines may result in the denial of warranty claims.

For technical assistance:

Europe: service@oceanled.com

The Americas: warranty@oceanledusa.com

Warranty Serial Code(s):

© 2024 Ocean LED Marine LTD
All Rights Reserved

Specifications are subject to change without notice.

Trademarks are the property of Ocean LED Marine LTD

Ocean LED Marine LTD
Unit 1 Jacknell Road
Dodwells Bridge Industrial Estate
Hinckley,
Leicestershire LE10 3BS
United Kingdom

Tel: +44 (0) 1455 637505
sales@oceanled.com

Ocean LED USA LLC
778 South Military Trail
Deerfield Beach
Florida
FL 33442-3025
USA

Tel: +1 954.523.2250
sales@oceanledusa.com

www.oceanled.com